



GSW OFFICE

Functional office
space design

COVER PHOTO

Horizon | Warsaw

Design studio: Workplace

Table of contents

About Glass System	4
Modern office	8
Glass wall systems	10
Certification	12
GSW Office	18
GSW Office Plus	30
GSW Office FR	42
GSW Office Plus FR	48
GSW Office doors	54
Fittings and accessories	70
Lante Intelli switches and readers	75
Wall Up baseboards	76
Test reports	78

version KP.GO.2022.IX.EN

The producer reserves the right to change specifications and technical data of products. Photos of products and their finishes may differ from reality.



Glass System

At Glass System, we help to create friendly interiors, inline with contemporary trends in design and lifestyle. We are passionate about everything we do, that is why we're constantly searching for new paths and ideas.

We strive for innovation not only in terms of our products. We think out of the box in many aspects of our business. We create original solutions including glass wall systems for interiors. They are based entirely on our own, innovative projects.

We provide unique glass architecture systems, distinguished by a combination of eye-friendly aesthetics and guaranteeing safety and comfort functionalities. While developing our products, we pay attention to at the smallest detail. All of them together and individually make a difference, allowing to implement ambitious projects.

Our systems meet standards and legal requirements. All core Glass System products are provided with the European Technical Assessment.

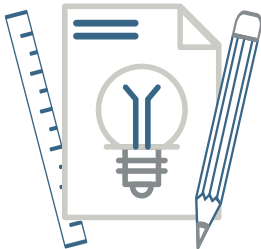

Original product solutions

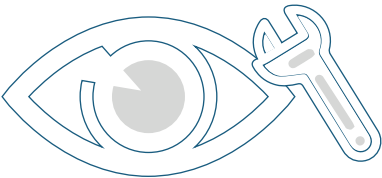

High aesthetics and functionality



Products with European Technical Assessment and CE marking



Business based on a synergy

Our business model is based on providing technology to specialised installation companies to whom we entrust the realization of projects. Synergy that is arising in this way helps us to build solid relations with our partners.



International scope of activity

One of our key strategic points is to build international reach of the brand thus we are constantly expanding our portfolio of international clients and trading partners. We increase Glass System presence on the European and other foreign markets.





Research and development

We perceive designing and developing our products as a continual process. Our competences in this regard were confirmed by the Polish Ministry of Economic Development by granting us prestigious status of Research and Development Center.

Our solutions are created entirely according to our own, original projects. All development works are conducted by an internal team of engineers who frequently cooperate with prestigious research facilities.

Glass System's Research and Development Department subjects new solutions to necessary research procedures

so that they meet all legal requirements - primarily in terms of fire resistance and acoustic insulation as well as safety and strength.

Over the years, we have developed a number of original solutions. Their innovation is confirmed by a dozen of utility models and patents, registered in Poland and abroad.

As a Research and Development Center, we develop also technologically advanced product solutions for our customers and partners.



Status of Research and Development Center granted by the Ministry of Economic Development



Cooperation with prestigious research facilities



Innovative solutions reserved in the Polish Patent Office

Production and logistics



As part of our activity, we offer comprehensive technical, production, and logistics support. A combination of our resources and competences allows us to offer a full range of services necessary for the arrangement of office space.

We support our clients during the implementation of every project, both in standard product application and individual solutions.

We own extensive production facilities equipped in specialised machinery enabling the implementation of even the most complex requests.

Our advanced warehouse space of 2 000 m² and logistic resources are at our customers disposal.



GSW Office Plus FR

Rooms for confidential conversations, limiting fire zones



p. 48

Wooden doors

Traditional door finishing and high acoustic insulation parameters



p. 68

GSW Office Plus

Director's offices and conference rooms – places for confidential talks



p. 30



Purian doors

Modern design - double glazing or wooden materials structurally glued to the profile hidden inside the door



p. 66

GSW Office

Rooms intended for focus work-requiring silence and proper lighting



p. 18

Glass doors

Light and delicate form, where door leaf creates an effect of continued surface in glass walls



p. 60

GSW Office FR

Corridors, evacuation routes and fire zone boundaries - partitions requiring fire protection



p. 42

Urban doors

Single or double glazed glass doors in an aluminum frame - high acoustic insulation while maintaining visual lightness



p. 62

GSW Pro

Entrance doors and walls in public facilities – partitions exposed to higher operational load

Learn more in the GSW Pro catalogue

GS Railing

Glass railings on the inside and on the outside – aesthetic finishing of the ceiling boundary and fall protection

Learn more in the GS Railing catalogue

Modern office

Modern office spaces are characterised by spaciousness, good lighting, care for decor and innovative solutions as well as fulfillment of the requirements of construction regulations.

Investors are becoming more and more aware of the value introduced by good arrangement of work space. They know how much employees appreciate harmonious surroundings, silence, interior ergonomics and proper lighting. All these factors have a profound effect on work quality and effectiveness.

Glass System products allow achieving the above aims and meet the regulatory requirements, so they can be used in almost every office arrangement.



Glass wall systems

Glass walls are an indispensable element in the division of modern interior space. Thanks to them, the rooms are full of light and appear optically larger than in case of limiting the space with traditional non-transparent walls. Glass wall systems can be used in spaces with very diverse purposes.

Individual places of application are specified in European standards in the form of category of space and category of use. The walls must meet specific requirements depending on these categories. Parameters in this respect depend both on the type of used glass as well as on the mounting system.

Category of space	Purpose	Category of use	
A	Residential	I/II	IV*
B	Office		
C	Meetings and gatherings	III	
D	Commercial		
E	Warehouse		

* In case of failure risk includes the fall to a floor at a lower level.
 Classification according to EN-1991-1-1 and EAD 210005-00-0505

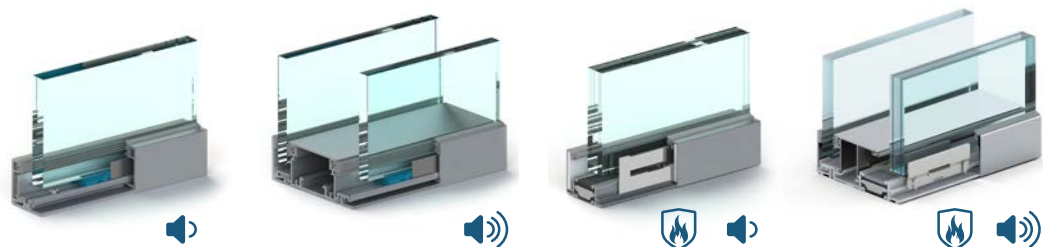

	GSW Office	GSW Office Plus	GSW Office FR	GSW Office Plus FR	
Typical purpose	Offices	Offices	Offices	Offices	
Category of use	III / IV	IV	IV	IV	
Profile height (mm)	35	35	35	35	
All-glass	Max. height (mm)	3200 / 3400	3400	3000	3200
	Type of glass	ESG 10, 12 VSG 55.X, 66.X, 88.2, 106.2	ESG 10, 12 VSG 55.X, 66.X, 88.2	Contraflam Structure 30 Pyrobel 16 VL, 16EG VL, 25 VL	Pyrobel 16 VL, 16 EG VL VSG 55.X, 66.X, 88.2
	Acoustic insulation	$R_w = 33 \div 41$ dB $R_{A1} = 31 \div 40$ dB	$R_w = 41 \div 52$ dB $R_{A1} = 39 \div 50$ dB	$R_w = 38 \div 42$ dB $R_{A1} = 36 \div 41$ dB	$R_w = 47 \div 53$ dB $R_{A1} = 46 \div 51$ dB
	Fire resistance	-	-	EI 15 / EI 30 / EI 60	EI 30, EI 60
Grid	Max. height (mm)	3400	4000	2800 / 3000	on request
	Type of glass	ESG 10, 12 VSG 55.X, 66.X, 88.2	ESG 8, 10, 12 VSG 44.X, 55.X, 66.X, 88.2	Contraflam 30 Pyrobel 16, 16 EG	
	Acoustic insulation	$R_w = 36 \div 41$ dB $R_{A1} = 35 \div 40$ dB	$R_w = 47 \div 57$ dB $R_{A1} = 44 \div 54$ dB	$R_w = 39 \div 41$ dB $R_{A1} = 38 \div 40$ dB	
	Fire resistance	-	-	EI 30	
Approval	CE / ETA	CE / ETA	CE / ETA	CE / ETA	

CE marking



All GSW glass wall systems were tested by the Building Research Institute according to the ETAG 003 / EAD 210005-00-0505 guidelines and have been provided with documents of European Technical Assessment (ETA), which allow CE marking.

Acoustic insulation



GSW Office, GSW Office Plus, GSW Office FR and GSW Office Plus FR systems were tested at a laboratory site by the Building Research Institute according to standard EN ISO 10140-2, confirming high acoustic insulation results.

Fire resistance



GSW Office FR and GSW Office Plus FR systems were tested by the Building Research Institute according to standard EN 1364-1, achieving fire resistance classification EI 15, EI 30 and EI 60, depending on the applied glazing.

European Technical Assessment

Using Glass System solutions guarantees the compliance with EU standards specified in law. Glass wall systems were tested according to EAD 210005-00-0505 guidelines for issuance of European Technical Assessment (ETA).

European Technical Assessment is the basis for use of CE marking, which enables introduction of a product on the European Union markets.

EAD 210005-00-0505



Strength

As part of verification, partitions were tested for strength against impact of a soft body weighing 50 kg, a hard body weighing 1 kg and against effect of horizontal linear loads. These tests covered all types of glass used in the systems.

Test results confirmed high performance and strength parameters of the GSW Office system. The highest, IV category of use was granted, which allows installation on the edge of the ceiling, where a risk of falling to the floor of the lower level occurs (b).

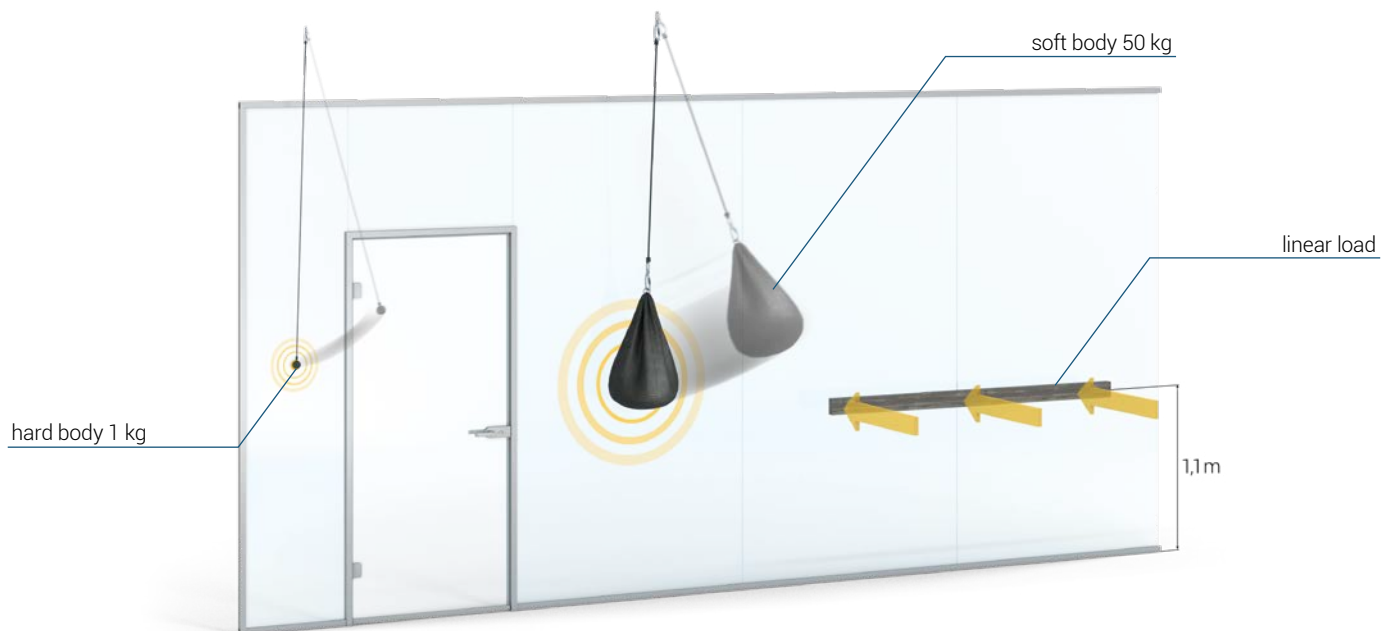
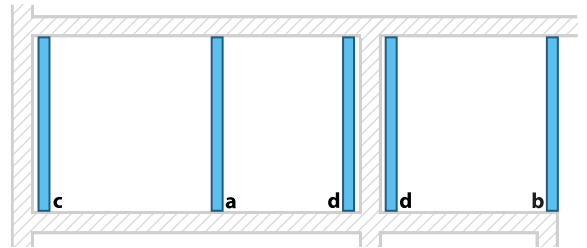

Acoustic insulation

GSW Office walls meet the criteria in terms of airborne sound insulation, required due to the nature of system's applications. This has been confirmed with tests performed at the Department of Acoustics of the Building Research Institute.

To determine parameters of airborne sound insulation, proper measurements are performed on laboratory research facilities according to the guidelines of standard EN ISO 10140-2, where sound transmission through flanking paths is suppressed. After launching the sound source on one side of partition, sound transmitted through

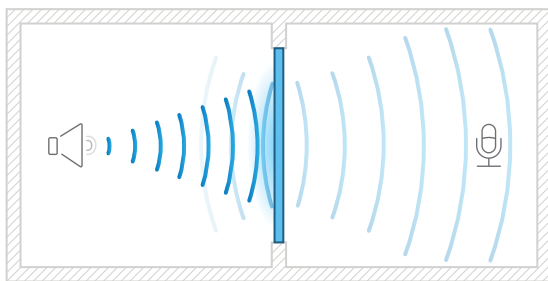

it is measured on the basis of differences in acoustic pressure on both of its sides.

To assess acoustic insulation of a partition with a specific purpose or to formulate requirements for acoustic insulation of internal partitions in buildings R_w and R_{A1} parameters are used, where:

$$R_{A1} = R_w + C$$

Acoustic requirements according to PN-B-02151-3:2015-10* - wall partitions

Type of room	Parameter	dB value
Office buildings		
Office rooms	R'_{A1}	≥ 40 (≥ 35) ⁱ
Rooms for confidential talks	R'_{A1}	≥ 50
Conference rooms	R'_{A1}	≥ 48

*Polish norm concerning building acoustics, noise protection in buildings and requirements for acoustic insulation of partitions in buildings

ⁱ it is allowed to adopt lower requirements if, due to other operational considerations, the requirement of $R'_{A1} \geq 40$ dB would have caused significant technical difficulties

Ranges of R_w parameter levels for GSW Office systems:

		30	31	32	33	34	35	36	37	38	39	40	41	42	43	44	45	46	47	48	49	50	51	52	53	54	55	56	57	58	59	60			
	GSW Office	33 ÷ 41 dB																																	
	GSW Office Grid													36 ÷ 41 dB																					
	GSW Office Plus																			41 ÷ 52 dB															
	GSW Office Plus Grid																									47 ÷ 57 dB									
	GSW Office FR													38 ÷ 42 dB																					
	GSW Office FR Grid																			39 ÷ 41 dB															
	GSW Office Plus FR																									47 ÷ 53 dB									

Fire resistance

Construction products are classified in terms of fire resistance on the basis of laboratory test results. In case of load bearing capacity of glass walls, most frequently occurring markings according to standard EN 13501-2 are the following:

- / **E**: Fire integrity – the partition blocks flow of hot gases and flames; nevertheless, the temperature of non-heated surface may reach several hundred degrees and there can be strong thermal radiation
- / **EW**: Fire integrity and limited heat radiation – apart from the guaranteed tightness in terms of hot gases and flames, the partition also limits heat transmission to the nonheated side up to 15 kW/m²
- / **EI**: Fire integrity and insulation – the partition ensures block of flow of hot gases and flames and does not allow the average temperature of the non-heated surface to increase by more than 140°C and the maximum temperature to increase by more than 180°C

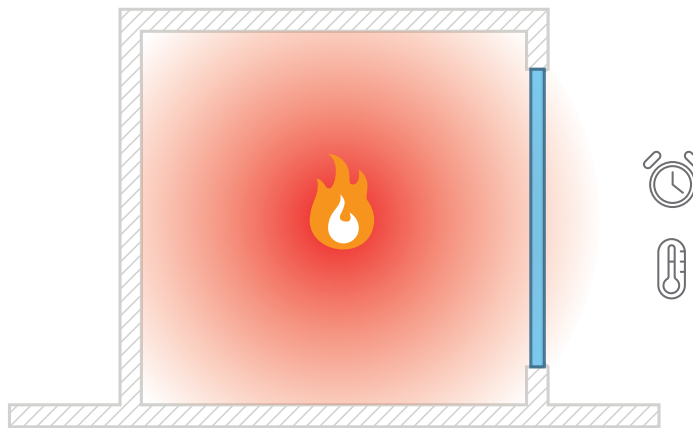

To verify characteristics of a given partition in terms of fire resistance, laboratory tests are made according to standard EN 1364-1. A glass wall made of panels with maximum permissible dimensions is installed in the opening of the research furnace, the furnace chamber is then closed and conditions to which the wall may be exposed during fire in the building are simulated. Temperature during test increases logarithmically, reflecting the conditions occurring during a fully developed fire. It is expressed with the following formula:

$$T = 345 \log_{10}(8\tau + 1) + 20$$

where:

- τ - time from the start of the test in minutes
- T - average temperature of the furnace in degrees

The level of thermal radiation on the non-heated side of the tested sample is measured with a radiometer and the temperature on the surface of the partition is measured with a set of thermocouples.

Fire glass is composed of many panels separated by special material. Under normal conditions, it provides full transparency, but in the case of fire, it expands and transforms into a rigid, non-transparent and heat absorbing insulation layer. To extend the time of protection against fire, glass with more such layers is most often used.

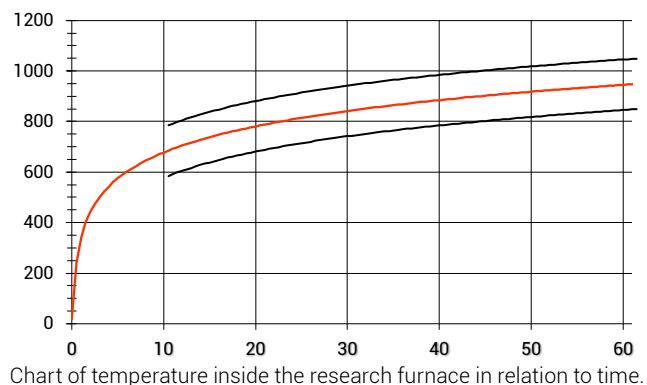

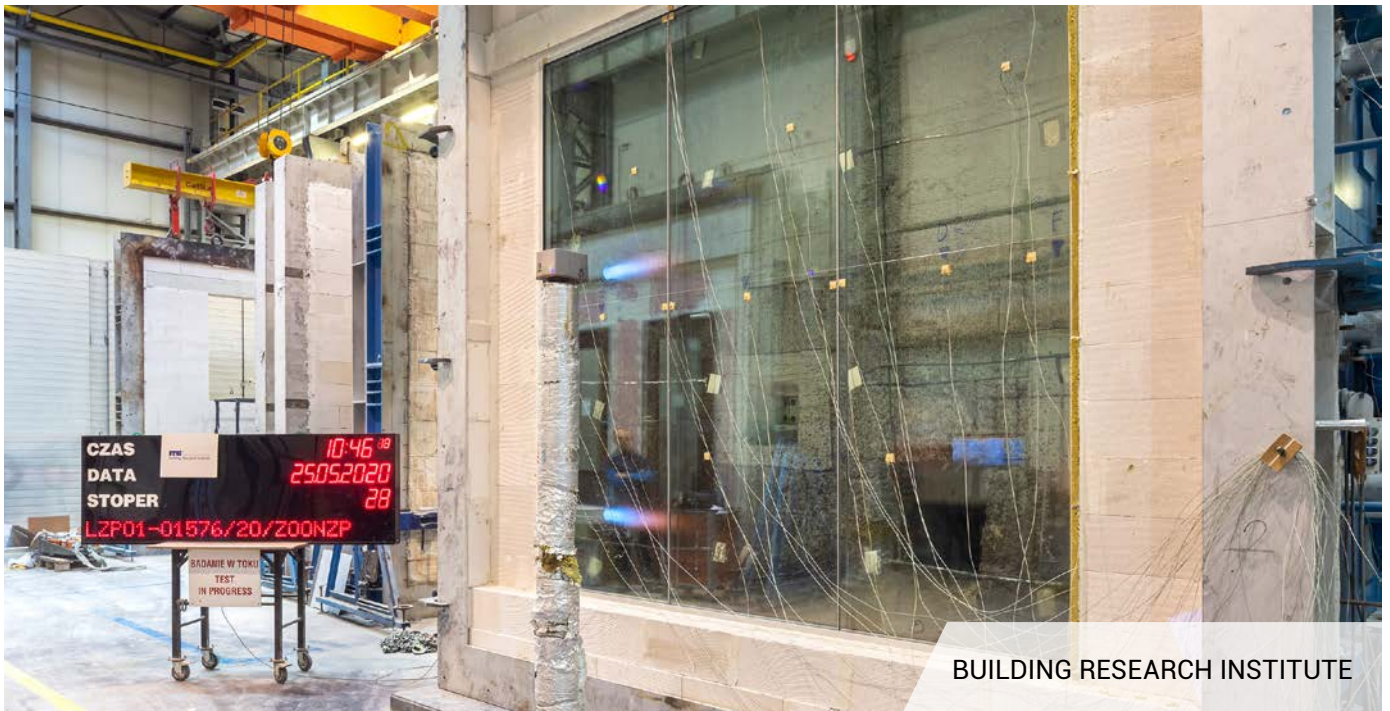

BUILDING RESEARCH INSTITUTE

Test results are determined in the following manner:

✓ **Integrity:** time (in full minutes) where none of the following conditions occur:

- ignition of a cotton pad put against partition surface for up to 30 s,
- formation of cracks or openings in the partition exceeding 25 mm at one point or 6 mm continuously at the distance of 150 mm,
- occurrence of flames on the non-heated side of the partition for longer than 10 s.

✓ **Heat radiation:** time (in full minutes) in which maximum level of thermal radiation measured at one-meter distance from the surface of the partition on the nonheated side does not exceed 15 kW/m².

✓ **Insulation:** time (in full minutes) within which the tested partition does not exceed the following criteria:

- increase of average temperature on the non-heated surface by 140°C above the initial temperature,
- increase of maximum temperature at any point on the non-heated surface by 180°C above the initial temperature.

Arrangement of measurement points on a model of the tested glass wall:

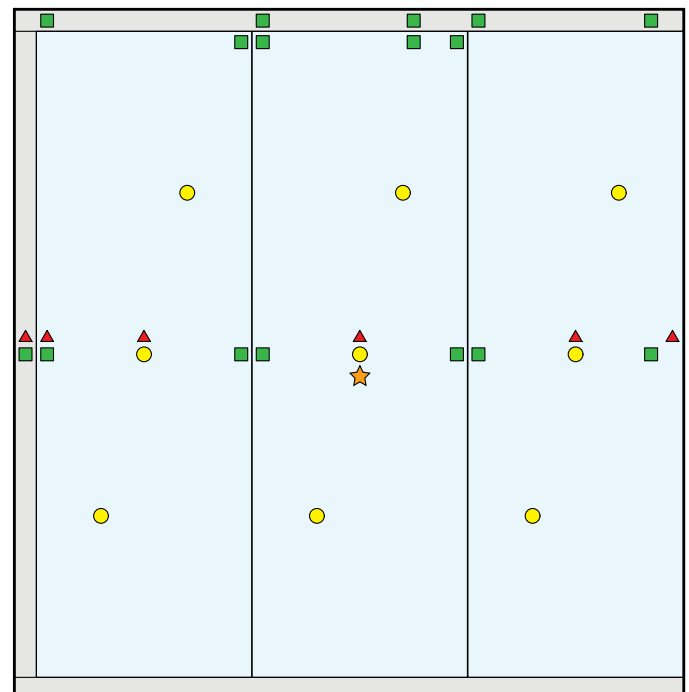

- thermocouples for average and maximum temperature
- thermocouples for maximum temperature
- ▲ places of deformation
- ★ places of radiation

Various functions

Consistent aesthetics



GSW Office

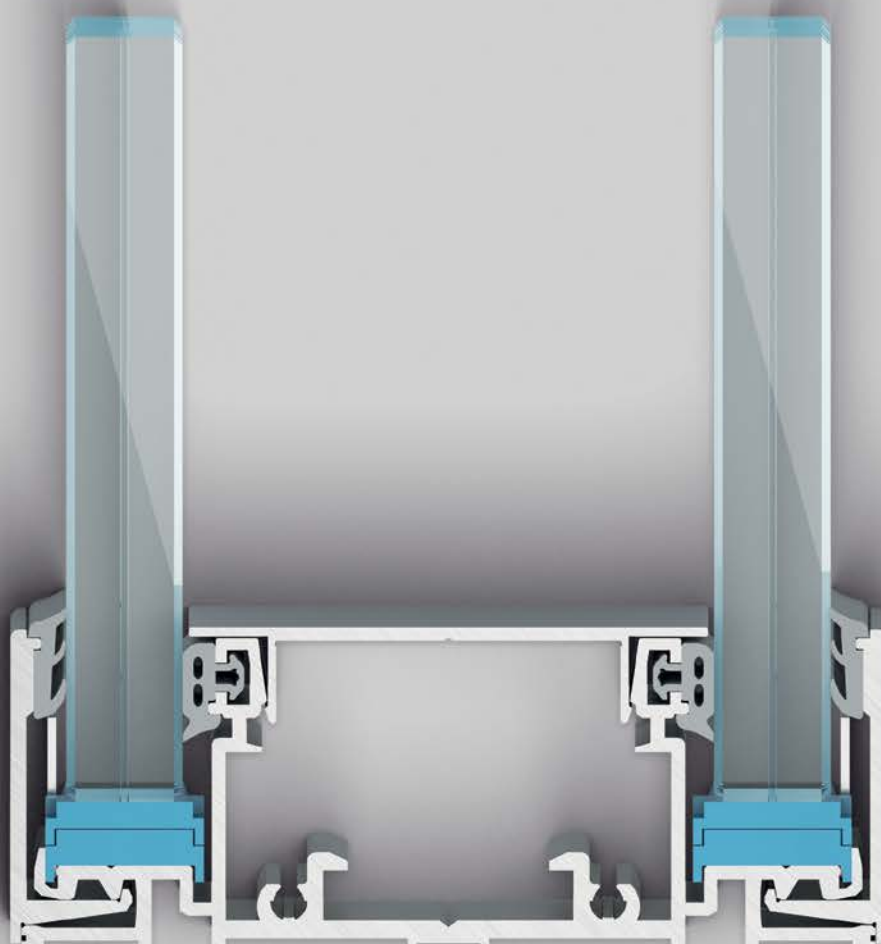

GSW Office Plus



35
mm

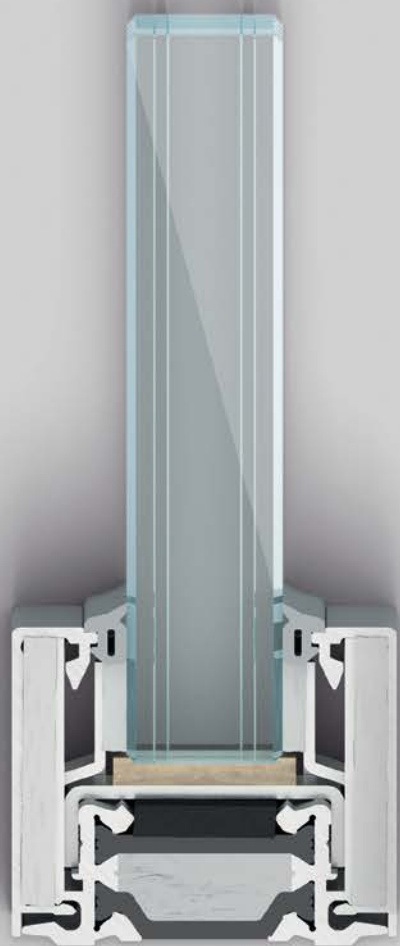

GSW Office FR

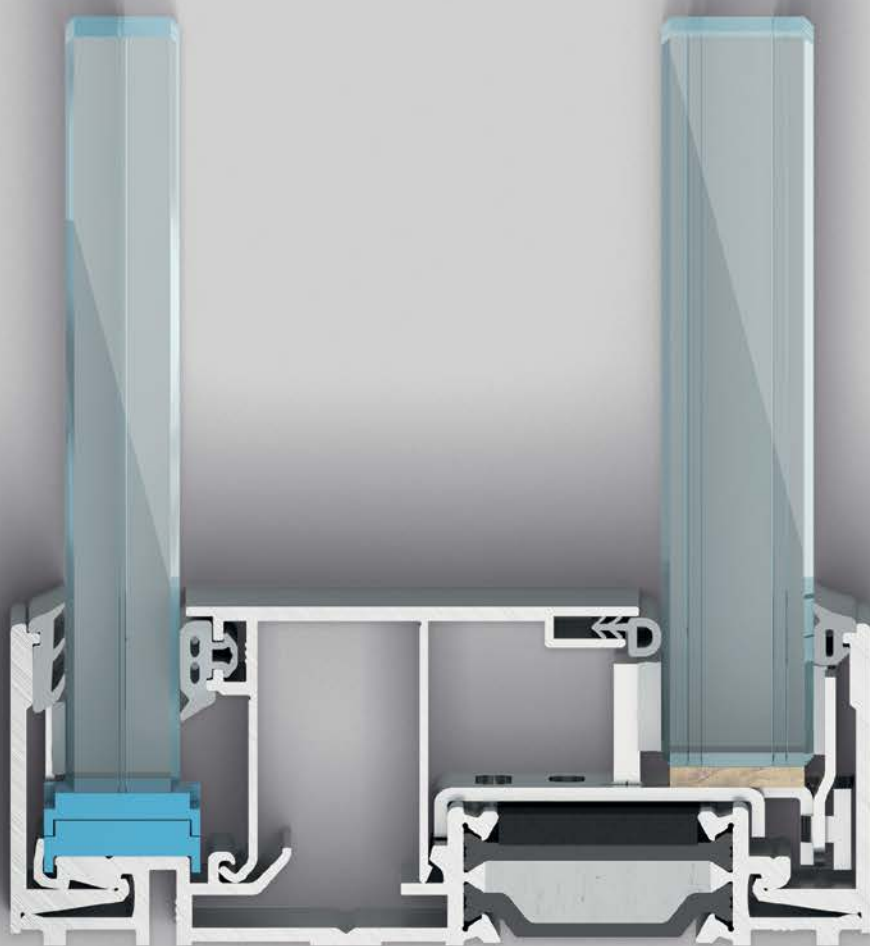

GSW Office Plus FR







GSW Office

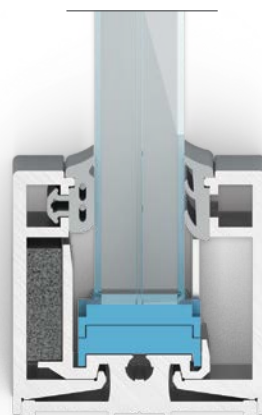

GSW Office

GSW Office is a single-glazed system that is the basis of the entire family of products intended for office partition walls. The system is characterised by a simple and aesthetic structure and versatility in application. It can be combined both with tempered and laminated glass

– including a variant with damping acoustic film. Thus, perfectly fits typical office rooms enhancing comfort and work effectiveness.

Specification	GSW Office	GSW Office Grid
Category of use	III / IV*	
Category of space	A, B, C, D, E	
Type of glass	ESG 10, 12; VSG 55.X, 66.X, 88.2, 106.2	ESG 10, 12; VSG 55.X, 66.X, 88.2
Max. height (mm)	3200 / 3400 mm*	3400 mm
Acoustic insulation	$R_w = 33 \div 41 \text{ dB} / R_{A1} = 31 \div 40 \text{ dB}$	$R_w = 36 \div 41 \text{ dB} / R_{A1} = 35 \div 40 \text{ dB}$
Fire resistance	-	-
Material / finish	Anodized aluminium / RAL aluminium	
Approval document	ETA-16/0446	

* depending on the applied glass

System features

- enhanced acoustic insulation parameters thanks to the innovative IsoSound solution reducing sound penetration through the profile,
- small 35 mm mounting profile, consistent with all GSW Office products,
- quick and convenient assembly thanks to a system of spacers and special elements protecting glass during installation.

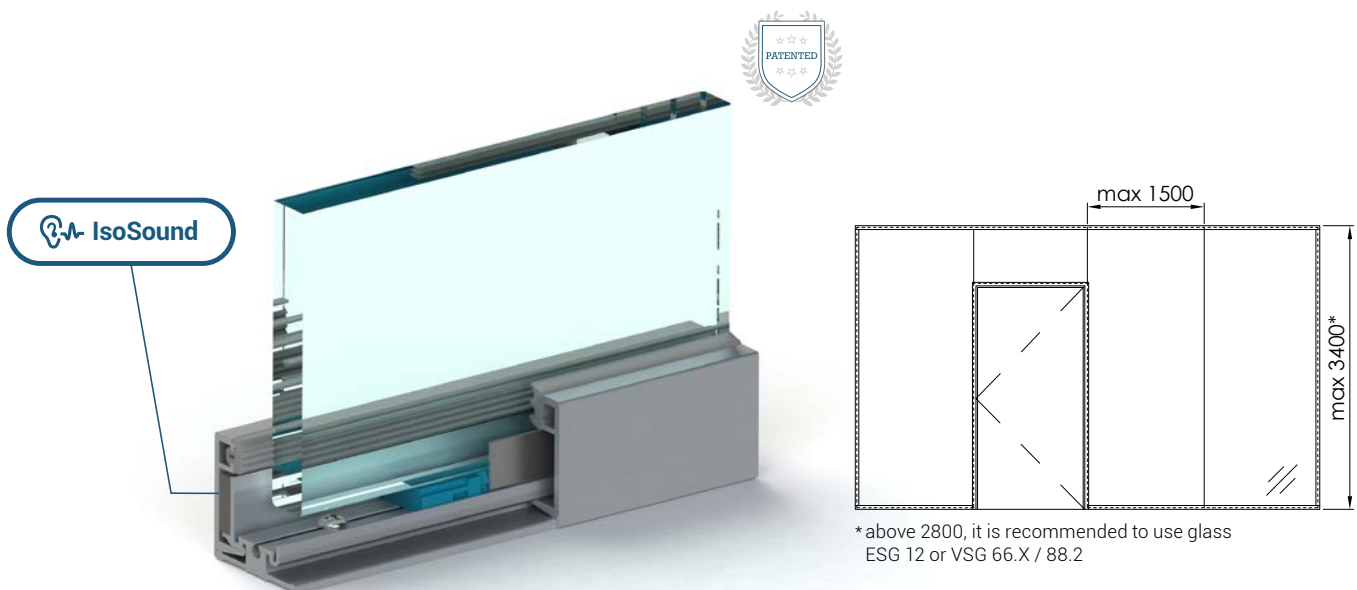

* above 2800, it is recommended to use glass ESG 12 or VSG 66.X / 88.2

IsoSound

The IsoSound filling is an integral part of the basic GSW Office system. By filling the empty space inside the profile, sound waves are damped to a better extent and combined with glass with acoustic film, the insulation parameters of the entire wall achieves the highest possible values for a one-pane structures.

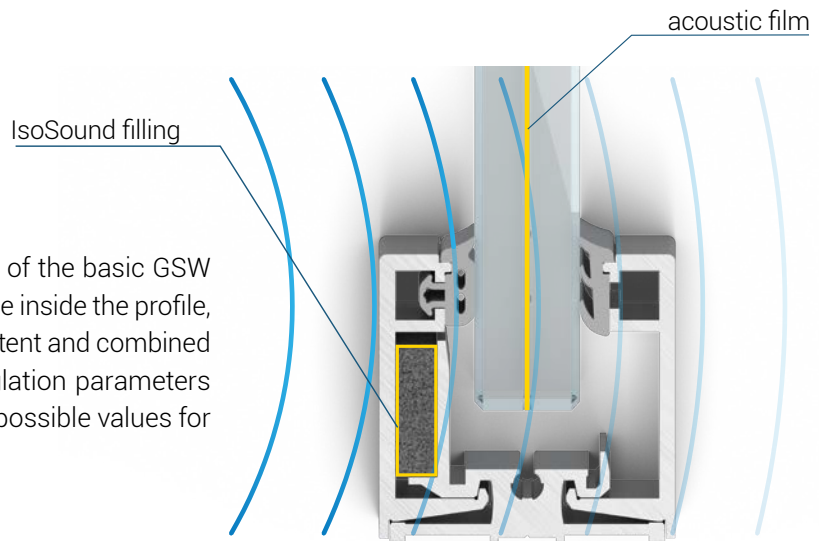

Glass	Wall insulation without IsoSound			Wall insulation with IsoSound			Increase of R_w / R_{A1}
	R_w [dB]	C [dB]	R_{A1} [dB]	R_w [dB]	C [dB]	R_{A1} [dB]	
55.1	34 ^{a)}	-2	32	35 ^{b)}	-2	33	+1
66.2 Silence	38 ^{a)}	-1	37	39 ^{c)}	-1	38	+1

^{a)}report number LA01-1839/15/Z00NA

^{b)}report number LZFO1-01028/17/Z00NZF

^{c)}report number LZFO1-03295/18/Z00NZF

Acoustic insulation

Wall variant	Glass	R_w [dB]	C [dB]	R_{A1} [dB]
All-glass	ESG 10	33	-2	31
	VSG 55.1	35	-2	33
	VSG 66.2	37	-2	35
	VSG 66.2 Si*	39	-1	38
	VSG 88.2 Si*	40	-1	39
	VSG 106.2 Si*	41	-1	40
Grid	VSG 55.1	36	-1	35
	VSG 66.2	37	-1	36
	VSG 66.2 Si*	40	-1	39
	VSG 88.2 Si*	41	-1	40

*Si - Saint-Gobain Glass Stadip Silence



BOBO COWORKING | WARSAW (PL)

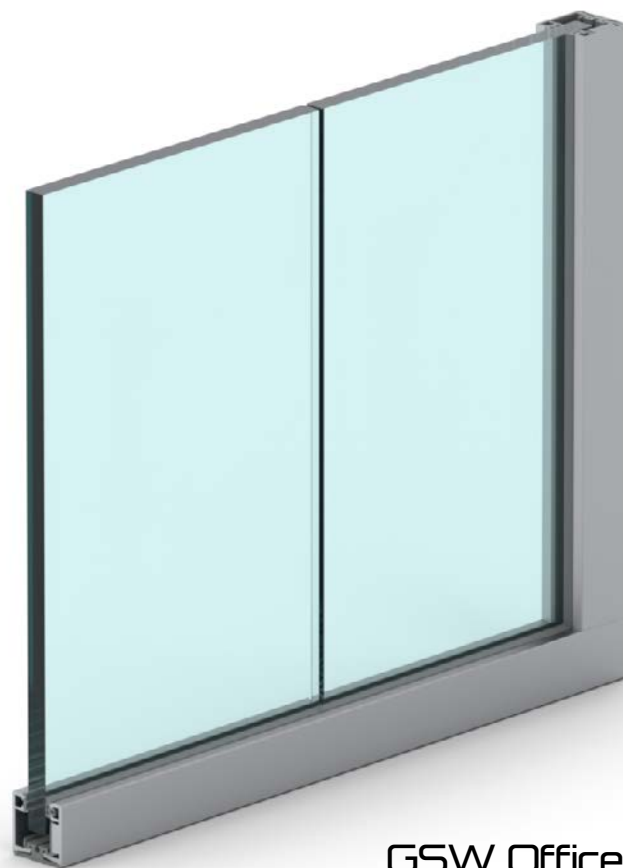
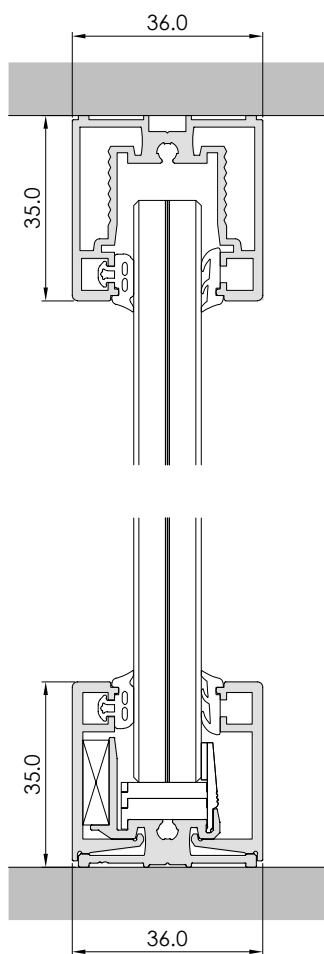

GSW Office

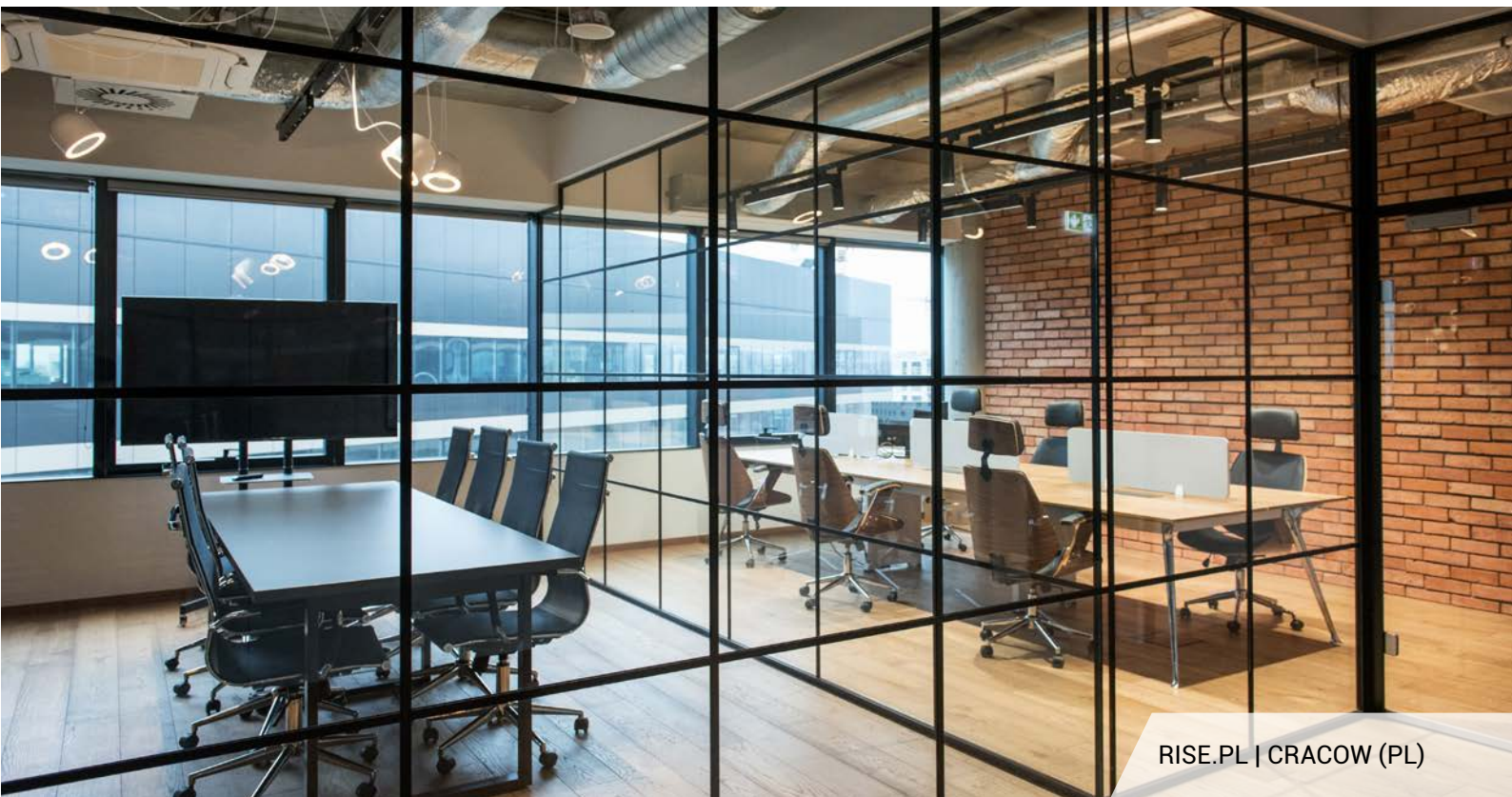

RISE.PL | CRACOW (PL)

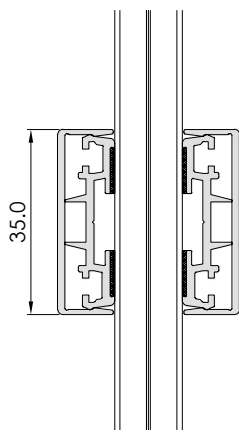
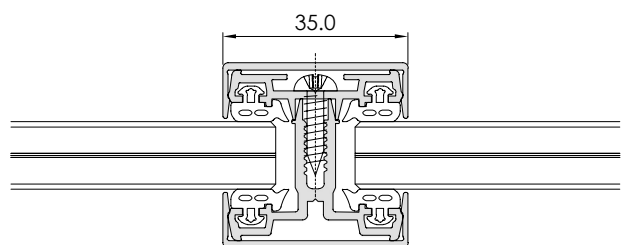

GSW Office Grid

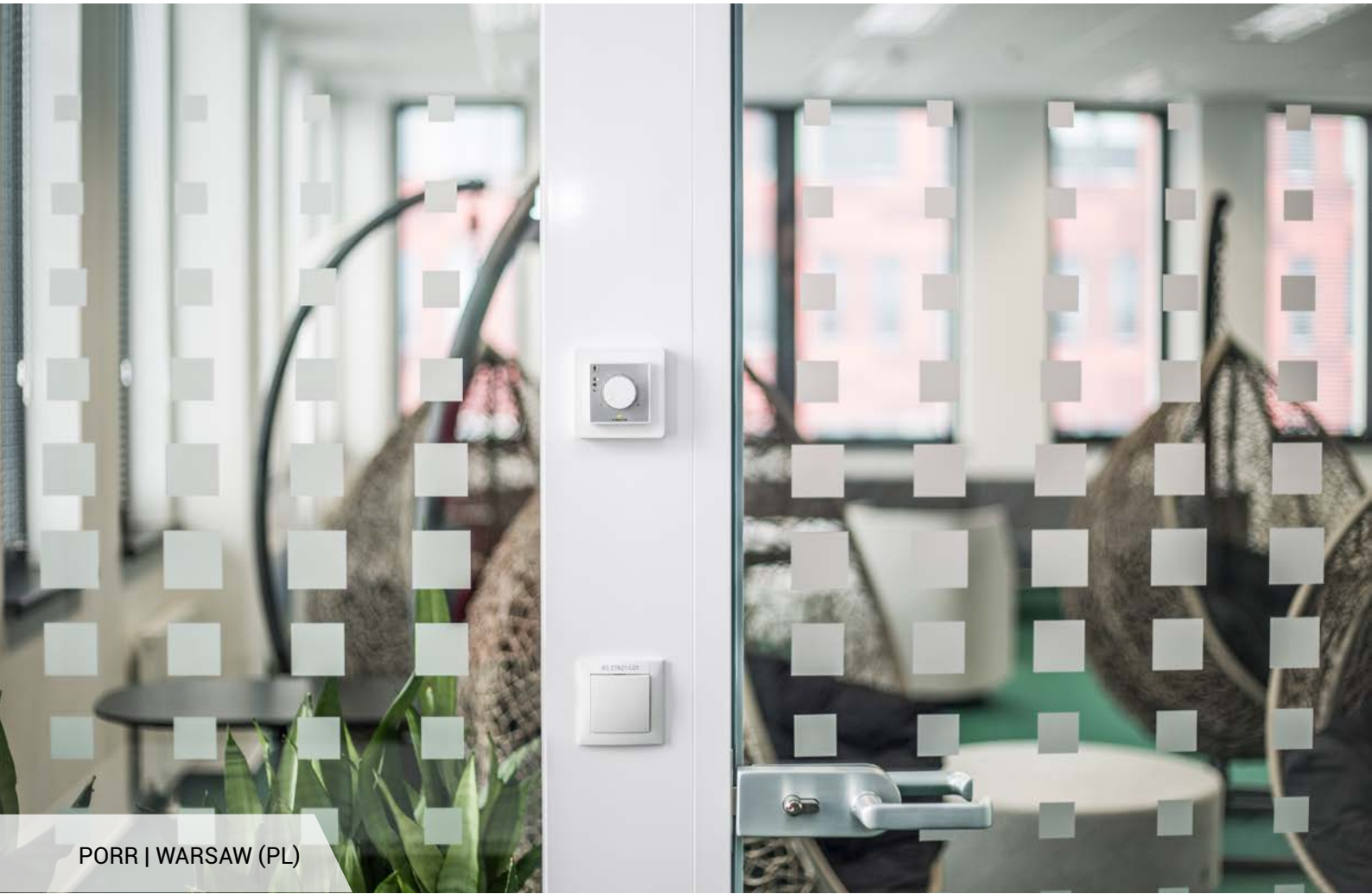

PORR | WARSAW (PL)

Installation panel

GSW Office Panel is a vertical element of the glass wall designed to provide the necessary installations like light switches, air conditioning controllers, access control readers etc.

This solution can also be used in the perpendicular connection of glass wall with drywall, covering its frontal edge.

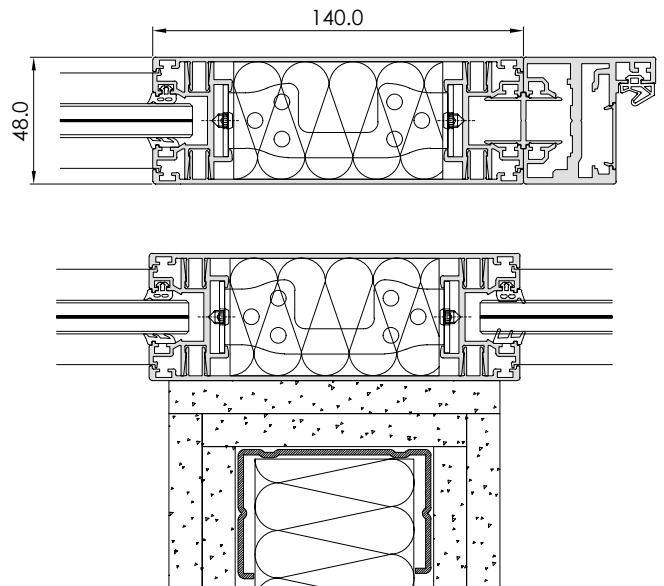



GLASS SYSTEM | WARSAW (PL)

Custom installation panel

A variant of the panel that allows non-standard use of various types of screens and controllers which are placed inside the panel. The dimensions can be adjusted to individual needs which enables greater freedom in design.

The individualisation of the panel also applies to finishing materials. The panel can be made of glass - perfectly matching the wall surface - or, for example, wood, referring to other interior elements.

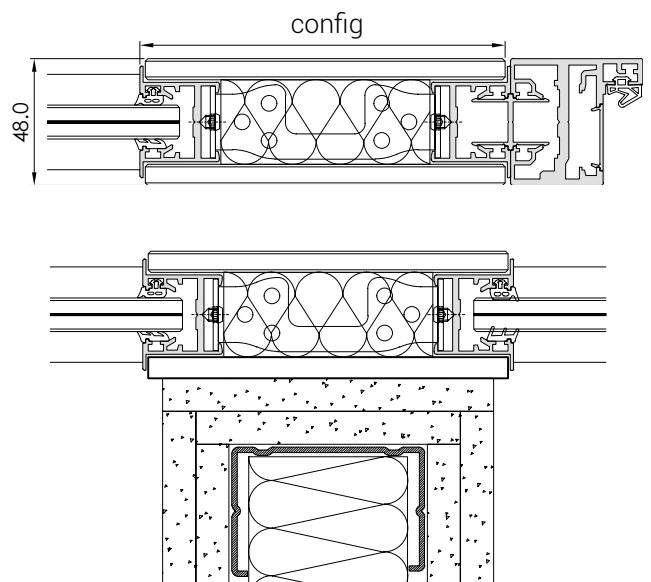

Rising profile

A system solution for mounting lining near the bottom edge of the wall is a rising profile used under the base profile. It raises the entire system by 6 mm, remaining not visible after installation and allowing the finishing of the lining where edges are not visible.

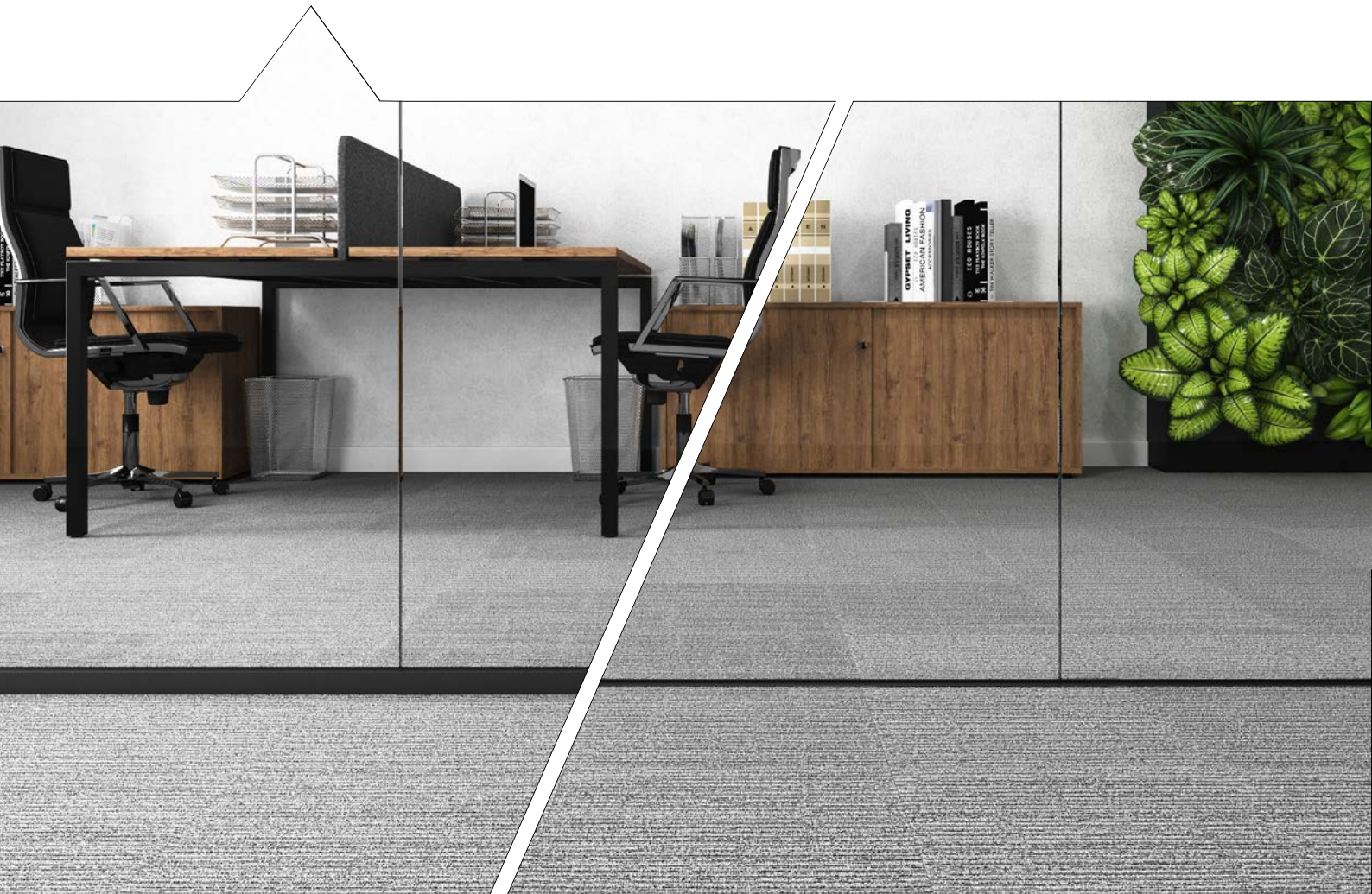
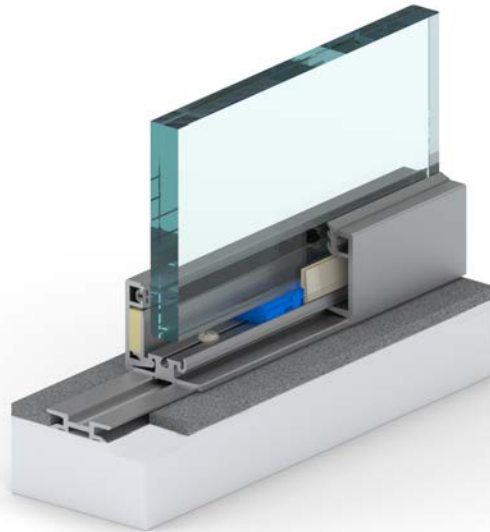
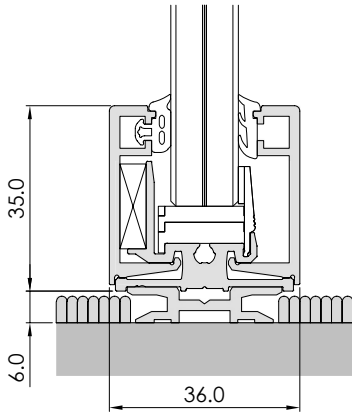

Hidden profiles

The GSW Office system is complemented by hidden profiles that allows achieving the consistent surface of the glass on the entire wall. The upper profile is used to hide the mounting profile in the suspended ceiling. The bottom profile allows you to hide the glass in the floor. The solution consists of an invisible base profile and separate covers with mounting height tolerance, thanks to which it is possible to level floor unevenness. There are alternative variants available, that can be used both in the classic and raised floor.

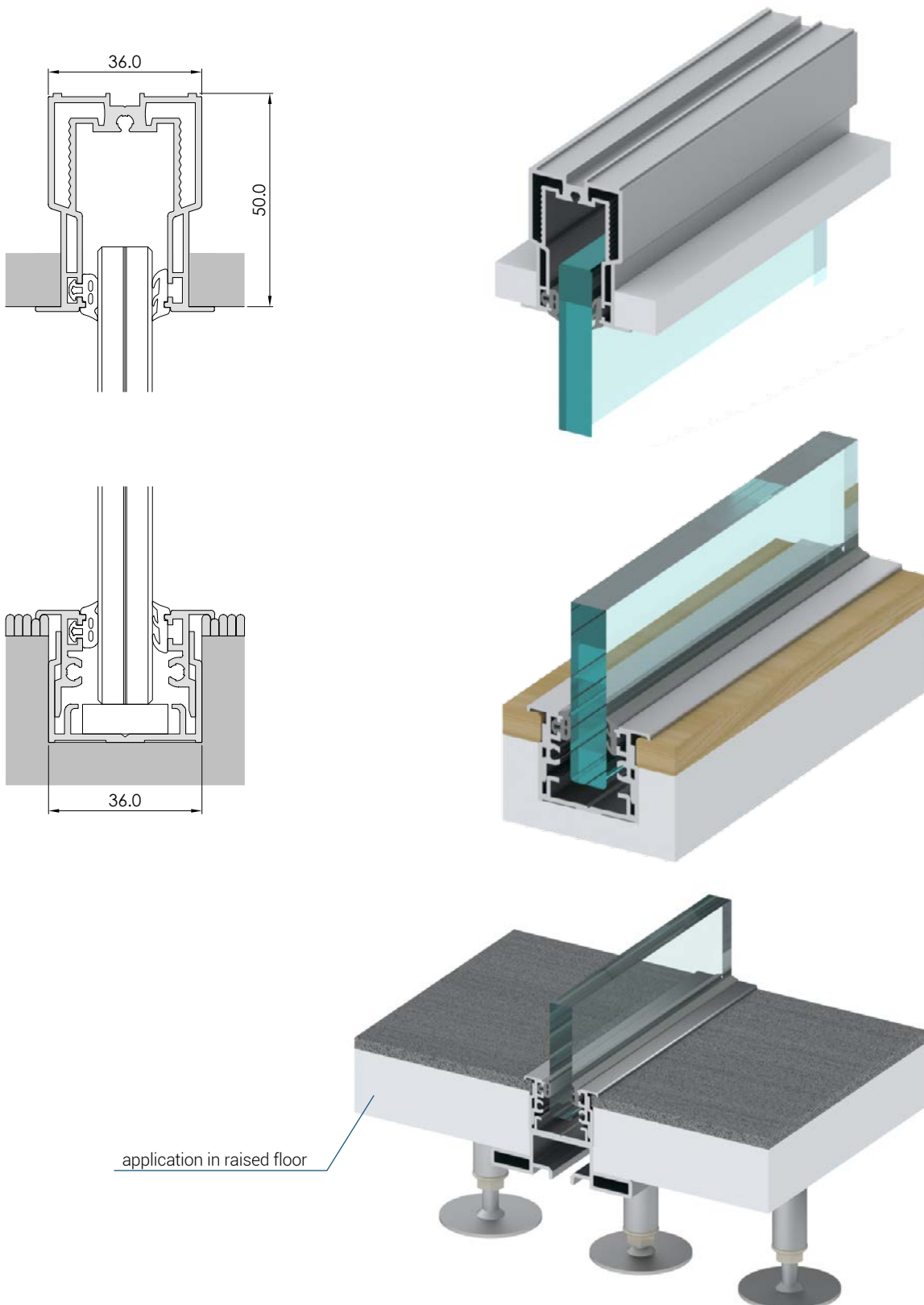

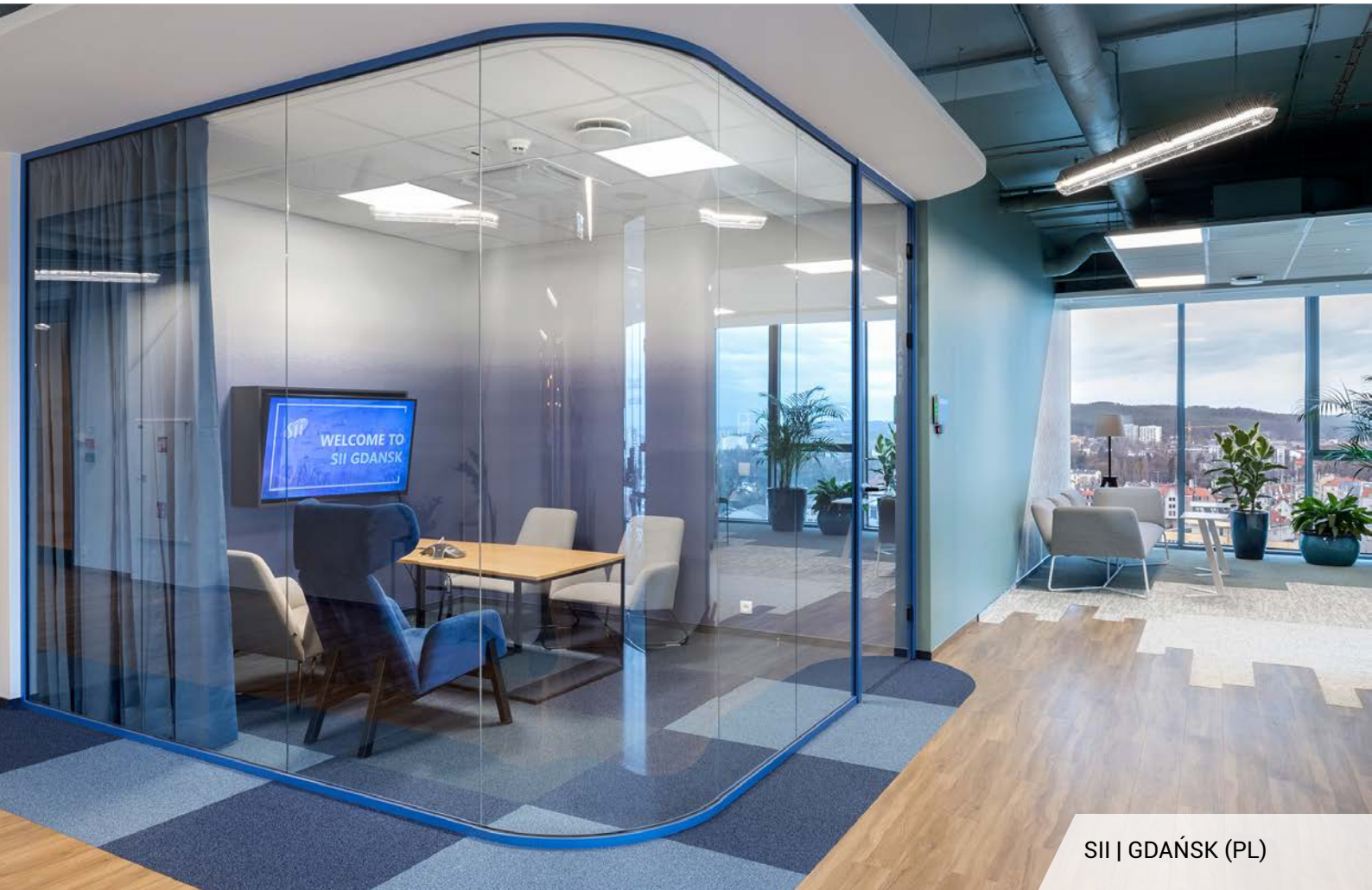

SII | GDAŃSK (PL)

Bent walls

The GSW Office system enables architects to implement unusual, impressive projects thanks to the possibility of rounding the corners of the rooms.

The bent walls in the corridors are also functional in terms of freedom of movement and safety.

The minimum internal bending radius of the GSW Office profile is 800* mm and enables the installation of any type of glass used in the system.

*the use of a smaller radius requires additional consultation

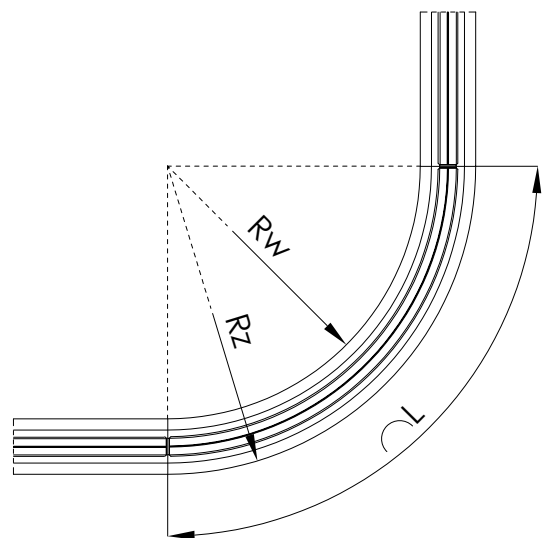



Walls with changing transparency

An effective way to separate private space is use of the technology of glass with changing transparency in the GSW Office walls.

Thanks to the liquid-crystal film placed inside laminated glass, it is possible to achieve the instantaneous effect of change from transparency to non-transparency.

In GSW Office system, walls with changing transparency use PRIVA-LITE glass made by Saint-Gobain.

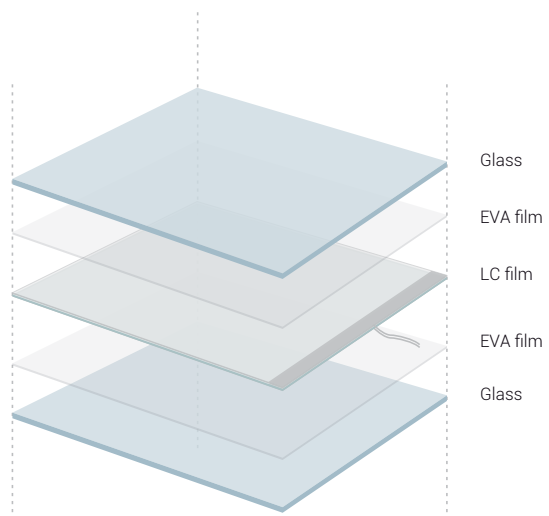





GSW Office Plus

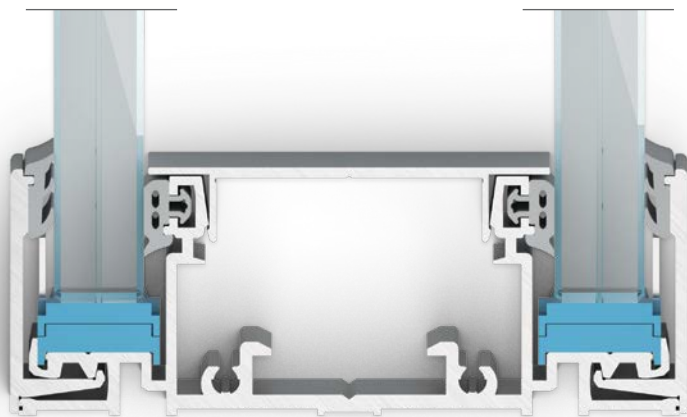

GSW Office Plus

GSW Office Plus is a double-glazed system with the highest acoustic insulation parameters out of all Glass System products - R_w even up to 57 dB. This is why it can be used in rooms for confidential talks, such as director's offices or in conference rooms as well as rooms for focus work. Importantly, the 35 mm height of the mounting

profile is consistent with all other products from the GSW Office family. Therefore, single- and double-glazed walls can be successfully joined when arranging the interior.

Specification	GSW Office Plus	GSW Office Plus Grid
Category of use	IV	
Category of space	A, B, C, D, E	
Type of glass	ESG 10, 12; VSG 55.X, 66.X, 88.2	ESG 8, 10, 12; VSG 44.X, 55.X, 66.X, 88.2
Max. height (mm)	3400 mm	4000 mm
Acoustic insulation	$R_w = 41 \div 5$ dB / $R_{A1} = 39 \div 50$ dB	$R_w = 47 \div 57$ dB / $R_{A1} = 44 \div 54$ dB
Fire resistance	-	-
Material / finish	Anodized aluminium / RAL aluminium	
Approval document	ETA-17/1050	





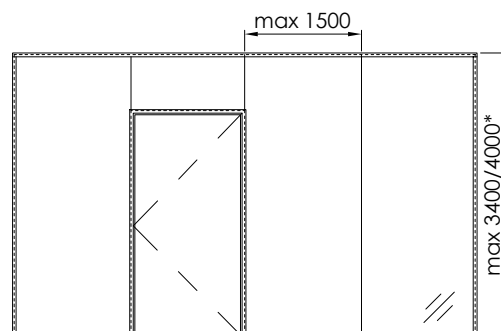



System features

- the highest acoustic insulation parameters – R_w even up to 57 dB – for office rooms requiring the highest level of privacy,
- mounting profile 35 mm high, consistent with all GSW Office products,
- quick and convenient assembly thanks to a system of spacers and special elements protecting glass during installation.

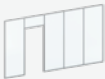

*depending on the system version

Acoustic insulation

Wall variant	Glass	R _w [dB]	C [dB]	R _{A1} [dB]
All-glass 	ESG 10 + ESG 10	41	-2	39
	ESG 10 + VSG 55.1	43	-1	42
	VSG 55.1 + VSG 66.2	44	-2	42
	VSG 66.2 + VSG 66.2	44	-1	43
	VSG 66.2 + VSG 66.2 	48	-2	46
	VSG 66.2 Si* + VSG 55.1	45	-2	43
	VSG 66.2 Si* + VSG 55.2 Si*	47	-2	45
	VSG 66.2 Si* + VSG 66.2 Si*	48	-1	47
	VSG 66.2 Si* + VSG 66.2 Si* 	52	-2	50
	VSG 88.2 Si* + VSG 88.2 Si*	51	-1	50
endoGrid  	VSG 66.2 / VSG 66.2	49	-3	46
	VSG 66.2 Si* / VSG 66.2 Si*	52	-3	49
	VSG 66.2 Si* / VSG 66.2 Si* 	56	-3	53
	VSG 66.2 / VSG 66.2	53	-2	51
	VSG 66.2 Si* / VSG 66.2 Si*	56	-2	54
egzoGrid  	VSG 44.1 / VSG 55.1	47	-3	44
	VSG 66.2 Si* / VSG 66.2 Si*	51	-1	50
	VSG 66.2 Si* / VSG 66.2 Si* 	55	-2	53
	VSG 44.1 / VSG 55.1	50	-2	48
	VSG 66.2 Si* / VSG 66.2 Si*	53	-1	52

endoGrid - internal muntins
egzoGrid - external muntins

*Si - Saint-Gobain Glass Stadip Silence

Akustic

To achieve maximum acoustic insulation, it is possible to use an innovative, patented solution with special

absorbing material placed around the circumference of the wall and, as an option, in inter-pane posts.

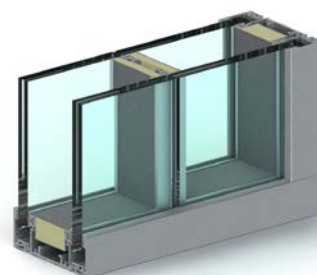
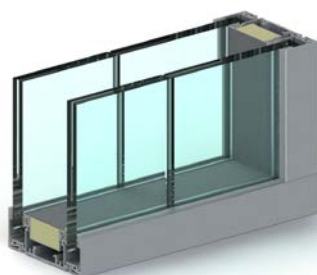



SIEMENS | WARSAW (PL)
PROJECT STUDIO: MASSIVE DESIGN

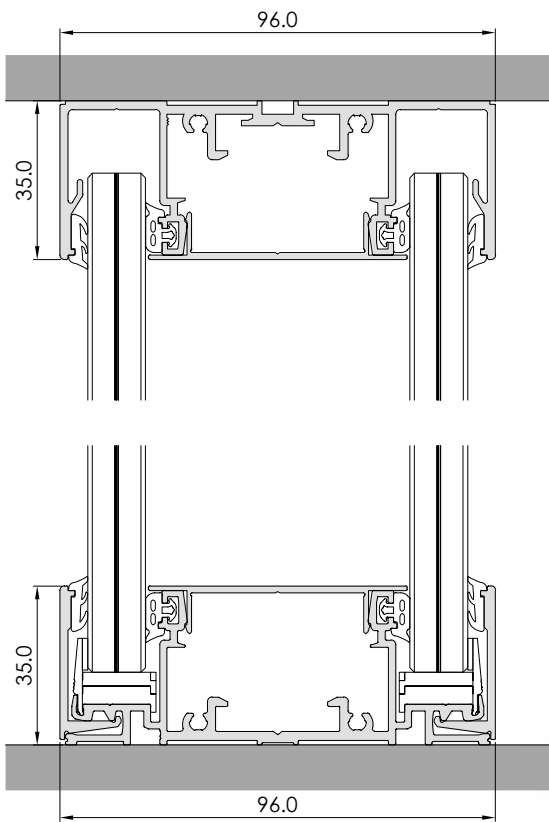

GSW Office Plus

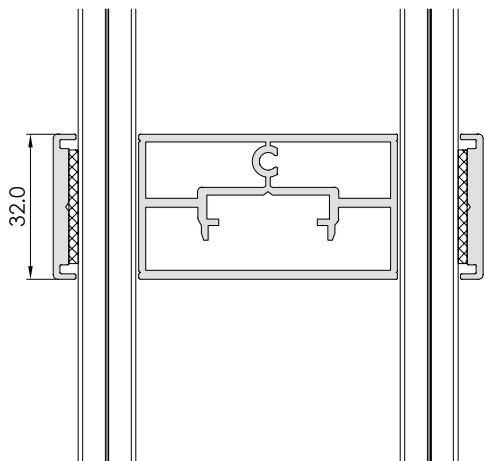
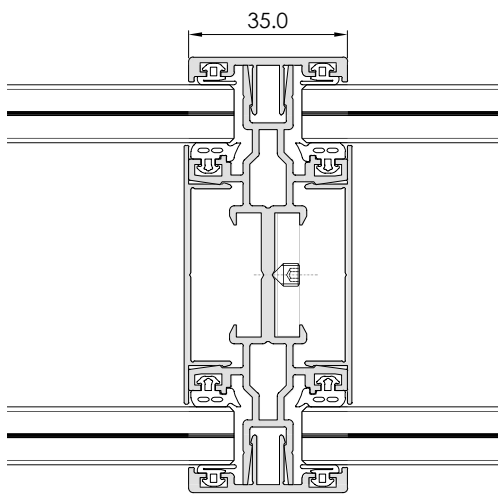
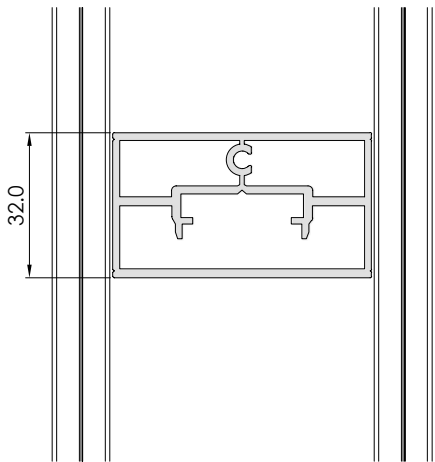
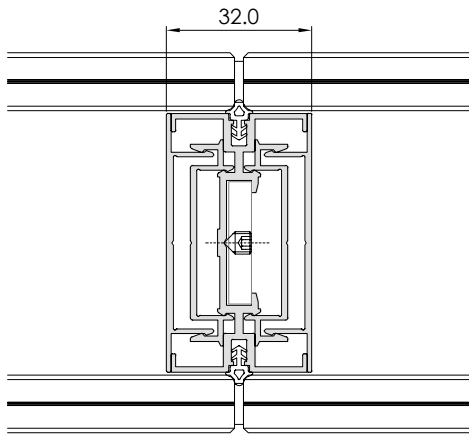

GSW Office Plus
endoGrid



GSW Office Plus
egzoGrid



IDEA BANK | GDAŃSK (PL)

Installation panel

GSW Office Plus Panel is a vertical glass wall element, analogous to its one-pane counterpart and designed to provide the necessary installations or a perpendicular connection of a glass wall with a drywall.

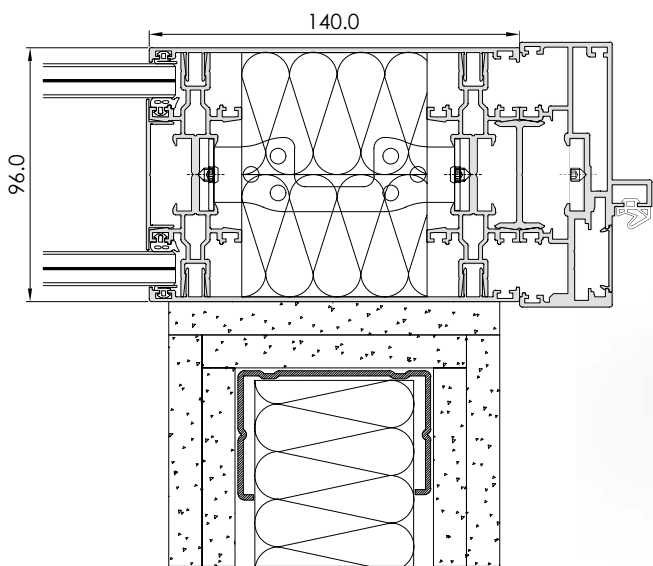

example application

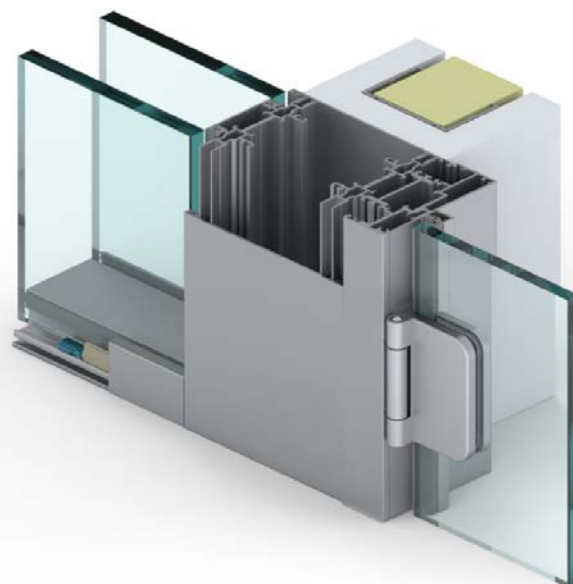



LIBRA BUSINESS CENTRE | WARSAW (PL)



GLASS SYSTEM | WARSAW (PL)

Custom installation panel

A variant of the panel that allows non-standard use of various types of screens and drivers in double-glazed systems, which are placed inside the panel. The dimensions can be adapted to individual needs, which gives greater freedom in design.

The individualisation of the panel also applies to finishing materials. The panel can be made of glass - perfectly matching the wall surface - or, for example, wood, referring to other interior elements.

application with egzoGrid panel

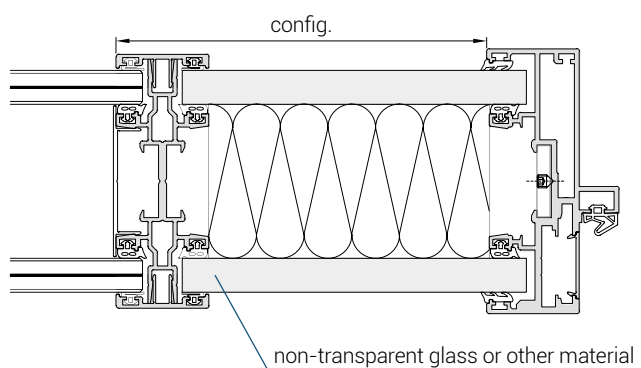

application with endoGrid panel

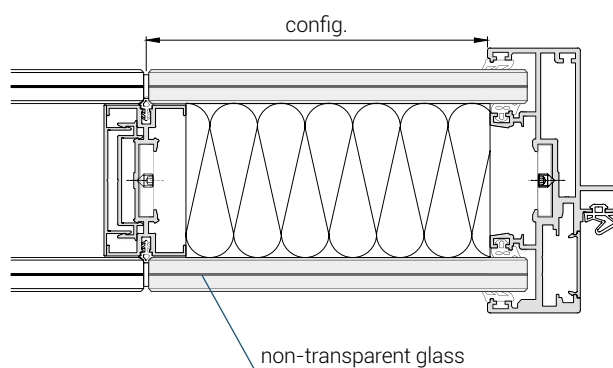



Additional profiles

Similarly to the single-glazed version, the system includes a solution allowing the mounting of lining at the bottom edge of the wall in the form of a rising profile used under the base profile. It allows finishing the lining so that its edges are not visible.

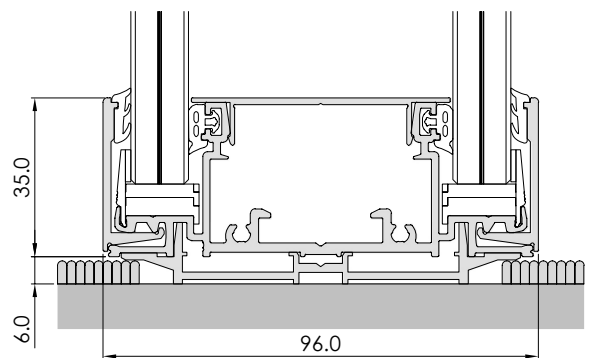

Similar to the one used in the single-glazed version, a variant of a bottom profile concealed in the flooring is available. Such a solution is composed of a non-visible base profile and separate covers with a tolerance for mounting height – therefore, it is possible to neutralise unevenness of the flooring.

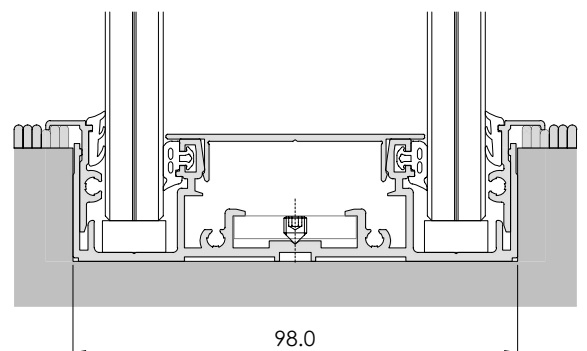

Bent wall

As in the single-glazed counterpart, also the GSW Office Plus system allows for rounding the corners of the rooms.

The minimum internal bending radius of the GSW Office Plus profile is 1100 mm*. In practice, this means greater flexibility in design, also in conference rooms and executive rooms, where increased sound insulation is required.

*the use of a smaller radius requires additional consultation

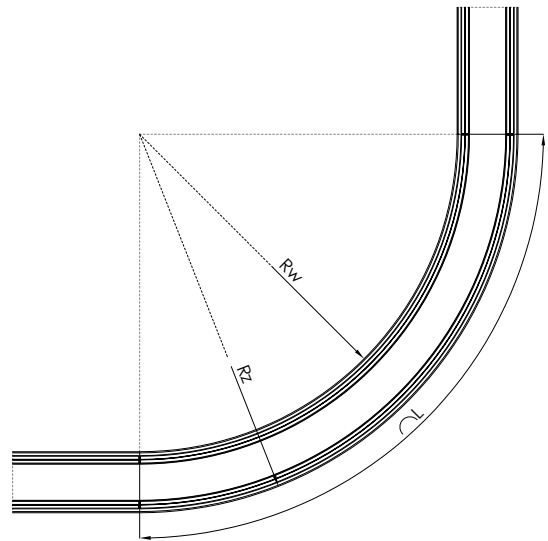

Dormax Blinds shutters

The system of automatic blinds developed in cooperation with Dormax-Blinds is a complete and elegant solution for the optical division of rooms with double-glazed GSW Office Plus walls. Control touchpad allows quick lowering, covering or lifting fully integrated shutters, depending on needs.

dormax
B L I N D S

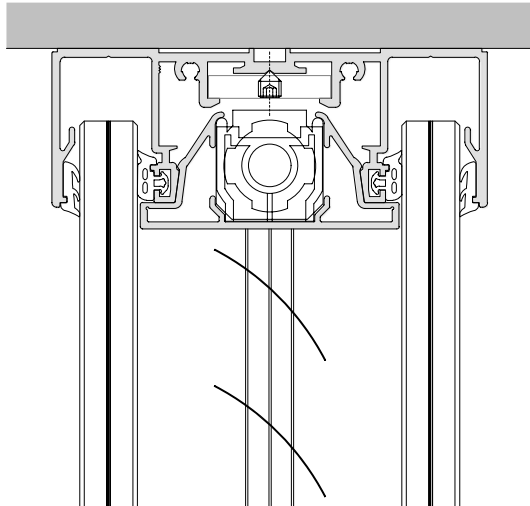

GLASS SYSTEM | WARSAW (PL)

Acoustic insulation

The main purpose of applying blinds and pleats is to provide privacy and separate the room from the rest of the space. An additional advantage of installing accessories is a significant increase in acoustic insulation in the rooms where they are used.

The GSW Office Plus system in combination with shutters allow achieving the highest acoustic insulation parameters of the entire GSW Office family - R_w 57 dB.

Blinds

Wall variant	Glass	Position	R_w [dB]	C [dB]	R_{A1} [dB]	increase of R_w [dB]**
All-glass	VSG 66.2 + VSG 66.2	closed	45	-1	44	+1
		open	48	-2	46	+4
	VSG 66.2 Si* + VSG 66.2 Si*	closed	49	-1	48	+1
		open	52	-2	50	+4
endoGrid	VSG 66.2 + VSG 66.2	closed	50	-2	48	+1
		open	52	-3	49	+3
	VSG 66.2 Si* + VSG 66.2 Si*	closed	53	-2	51	+1
		open	57	-3	54	+5
egzoGrid	VSG 44.1 + VSG 55.1	closed	48	-2	46	+1
		open	50	-2	48	+3
	VSG 66.2 Si* + VSG 66.2 Si*	closed	52	-2	50	+1
		open	54	-2	52	+3

Pleats

Wall variant	Glass	Position	R_w [dB]	C [dB]	R_{A1} [dB]	increase of R_w [dB]**
endoGrid	VSG 66.2 + VSG 66.2	raised	50	-2	48	+1
		lowered	52	-2	50	+3
	VSG 66.2 Si* + VSG 66.2 Si*	raised	53	-3	50	+1
		lowered	55	-2	53	+3
egzoGrid	VSG 44.1 + VSG 55.1	raised	47	-2	45	-
		lowered	49	-2	47	+2
	VSG 66.2 Si* + VSG 66.2 Si*	raised	51	-2	49	-
		lowered	53	-2	51	+2

endoGrid - internal grid
egzoGrid - external grid

*Si - Saint-Gobain Glass Stadip Silence

**Increase of R_w ratio compared to all-glass variant of the system without accessories.





GSW Office FR

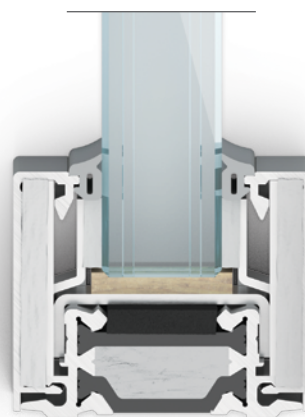

GSW Office FR

GSW Office FR is a single-glazed system - with and without grid variant - in line with existing fire and acoustic insulation regulations for office rooms.

It was developed in response to the belief that all walls in modern office should appear elegant and minimalistic. Depending on the used glass type, walls can have fire resistance from EI 15 to EI 60. The requirement to use fire-resistant glass does not mean, however, that it is necessary to resign from acoustic parameters – all glazing

variants in the GSW Office FR system underwent laboratory testing, which confirmed high parameters of acoustic insulation - R_w up to 42 dB.

The low profile of 35 mm guarantees full consistency with all GSW Office products.

Specification	GSW Office FR	GSW Office FR Grid
Category of use	IV	
Category of space	A, B, C, D, E	
Type of glass	Contraflam Structure 30 Pyrobel 16 VL, 16 EG VL, 25 VL	Contraflam 30 Pyrobel 16, 16 EG
Max. height (mm)	3000 mm	2800 / 3000 mm
Acoustic insulation	$R_w = 38 \div 42$ dB / $R_{A1} = 36 \div 41$ dB	$R_w = 39 \div 41$ dB / $R_{A1} = 38 \div 40$ dB
Fire resistance	EI 15 / EI 30 / EI 60	EI 30
Material / finish	Anodized aluminium / RAL aluminium	
Approval document	ETA-18/1097	

System features

- fire resistance depending on the used glass – EI15, EI30 or EI60 – allows to properly select wall parameters to meet the requirements of a given project,
- increased acoustic insulation parameters that meet the requirements for office rooms,
- profile height of 35 mm ensures not only attractive design, but also full consistency with all other products from the GSW Office family,
- innovative mounting system – steel elements fixing glass do not require screwing and are used for mounting cover profiles at the same time.

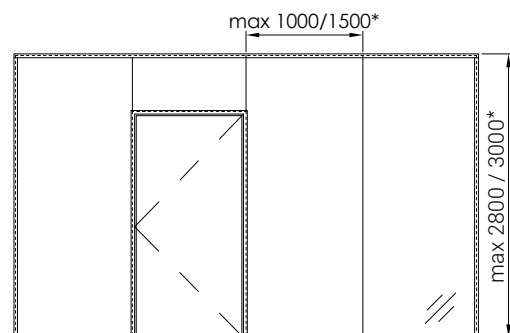
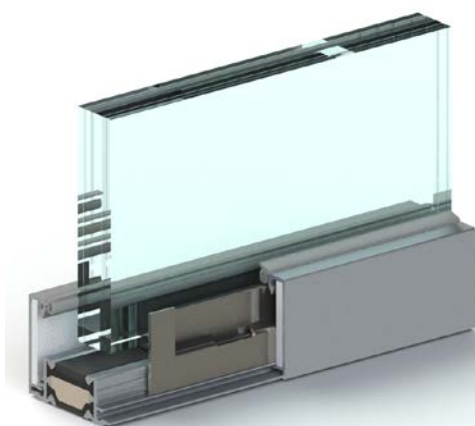

* depending on the applied glass and system version
Application, type and class of doors must be specified by the designer

Fire resistance and acoustic insulation

Wall variant	Glass	Fire resistance	R _w [dB]	C [dB]	R _{A1} [dB]
All-glass	Vetrotech Contraflam Structure Lite 30	EI 15	38	-2	36
	Vetrotech Contraflam Structure 30	EI 30	40	-2	38
	Vetrotech Contraflam Structure 30 Silence	EI 30	42	-1	41
	AGC Pyrobel 16 VL	EI 30	38	-1	37
	AGC Pyrobel 16 EG VL	EI 30	40	-1	39
	AGC Pyrobel 16 EG Stratophone VL	EI 30	41	-1	40
	AGC Pyrobel 25 VL	EI 60	42	2	40
Grid	Vetrotech Contraflam 30	EI 30	39	-1	38
	Vetrotech Contraflam 30 Silence	EI 30	41	-1	40
	AGC Pyrobel 16	EI 30	40	-1	39
	AGC Pyrobel 16 EG Stratophone	EI 30	41	-1	40

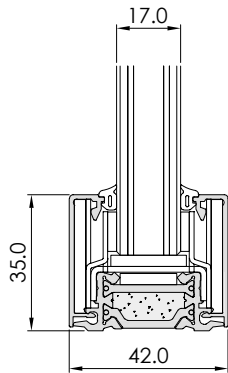

AGC Pyrobel 16 VL

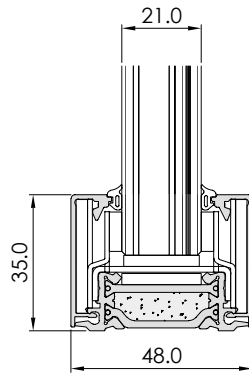

AGC Pyrobel 16 EG VL

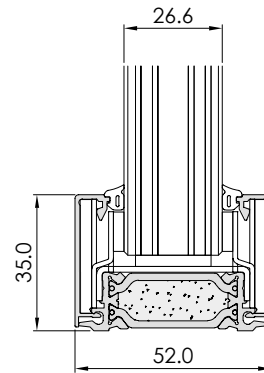

AGC Pyrobel 25 VL

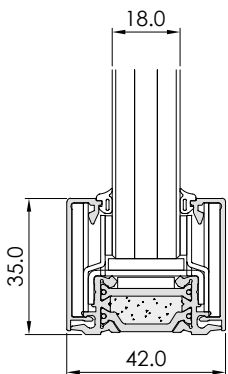

Vetrotech Contraflam 30

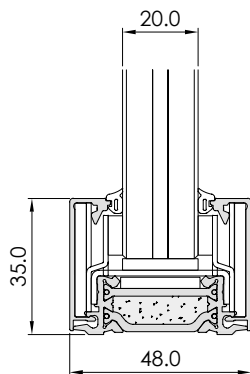

Vetrotech Contraflam Structure Lite 30

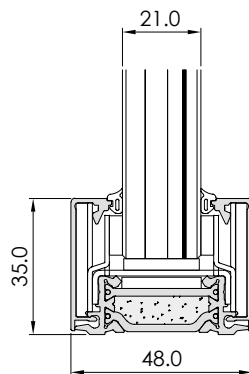

Vetrotech Contraflam 30 Silence

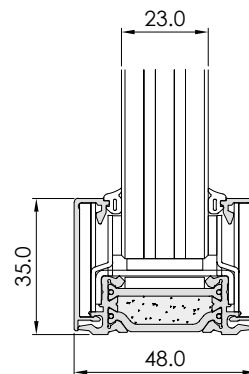

Vetrotech Contraflam Structure 30

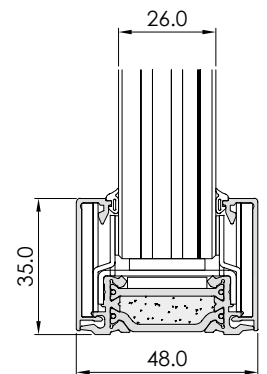

Vetrotech Contraflam Structure 30 Silence



CAMBRIDGE INNOVATION CENTER | WARSAW (PL)
PROJECT STUDIO: WORKPLACE

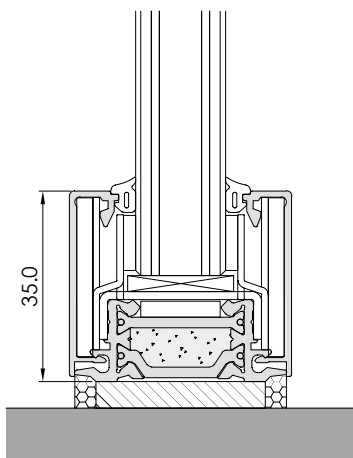
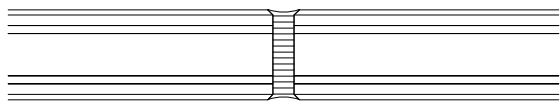

GSW Office FR
Vision Line

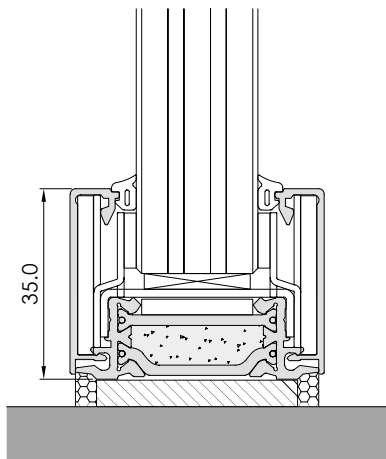
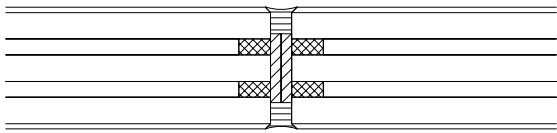

GSW Office FR
Structure

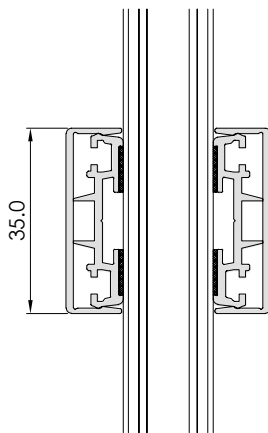
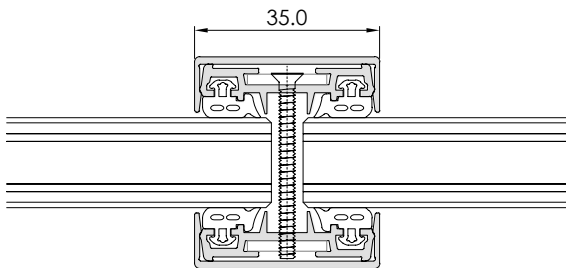

GSW Office FR Grid





GSW Office Plus FR

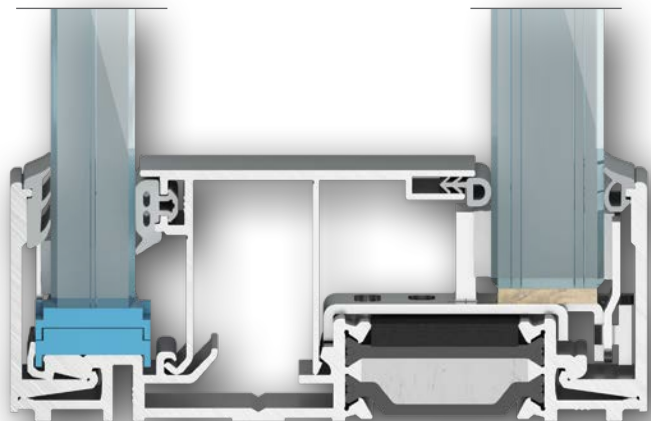

GSW Office Plus FR

GSW Office Plus FR is a double-glazed firewall system with high acoustic insulation parameters - R_w up to 53 dB. The system was designed for rooms intended for confidential conversations, such as directors' offices or conference rooms, limiting fire zones.

The system underwent laboratory testing using various glass combinations. The walls have fire resistance EI 30 or EI 60*.

At the same time, thanks to the use of a second pane of glass, it is possible to obtain high airborne sound insulation.

The profile is distinguished by high aesthetics - the height of 35 mm guarantees full integrity with other GSW Office products.

Specification	GSW Office Plus FR	GSW Office Plus FR Grid
Category of use	IV	on request
Category of space	A, B, C, D, E	
Type of glass	Pyrobel 16 VL, 16 EG VL VSG 55.X, 66.X, 88.2	
Max. height (mm)	3200 mm	
Acoustic insulation	$R_w = 47 \div 53$ dB / $R_{A1} = 46 \div 51$ dB	
Fire resistance	EI 30, EI 60	
Material / finish	Anodized aluminium / RAL aluminium	
Approval document	ETA-20/0630	

System features

- fire resistance depending on type of glass - EI 30 or EI 60 - allows for the proper selection of wall parameters to the project requirements,
- high sound insulation properties - R_w up to 53 dB - thanks to double glazing,
- 35 mm of mounting profile ensures not only lightness and aesthetics but also full integrity with all other GSW Office products.

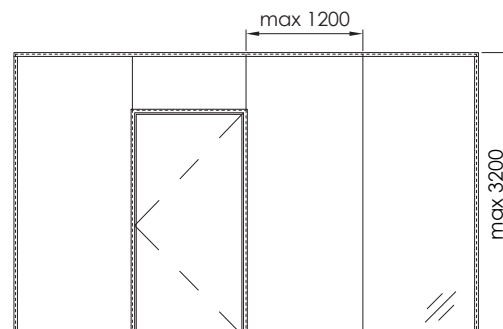

Application, type and class of doors must be specified by the designer

Fire resistance and acoustic insulation

Wall variant	Glass	Fire resistance	R _w [dB]	C [dB]	R _{A1} [dB]
All-glass	AGC Pyrobel 16 VL + VSG 55.1	EI 30	47	-1	46
	AGC Pyrobel 16 VL + VSG 66.2 Si*	EI 30	49	-1	48
	AGC Pyrobel 16 VL + VSG 88.2 Si*	EI 30	50	-1	49
	AGC Pyrobel 16 EG VL + VSG 88.2 Si*	EI 30	51	-1	50
	AGC Pyrobel 16 EG St** VL + VSG 88.2 Si*	EI 30	53	-2	51
	AGC Pyrobel 25 VL + VSG 66.2 Si*	EI 60	51	-1	50

*Si - Saint-Gobain Glass Stadip Silence

**St - Stratophone

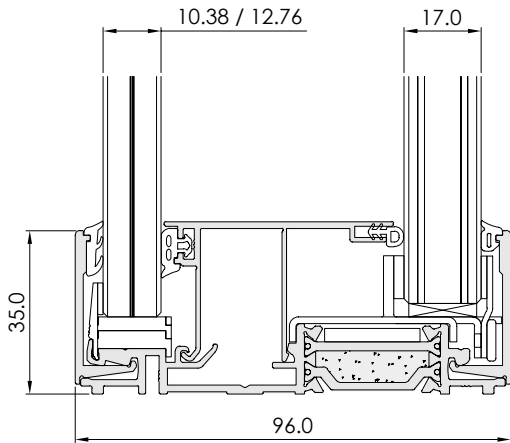

AGC Pyrobel 16 VL + VSG 66.2 Si

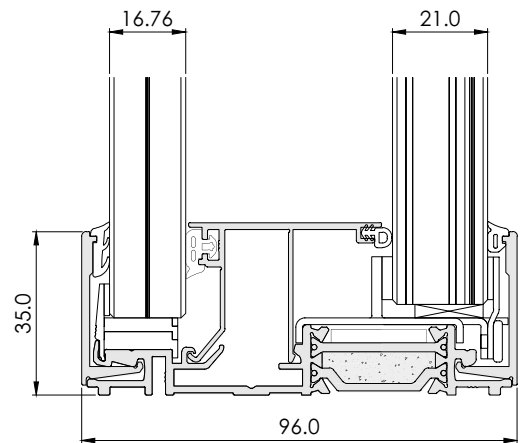

AGC Pyrobel 16 EG VL + VSG 88.2 Si



Watch a video animation presenting GSW Office Plus FR system

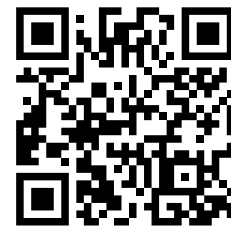

plusfr.glasssystem.com



GLASS SYSTEM | WARSAW (PL)

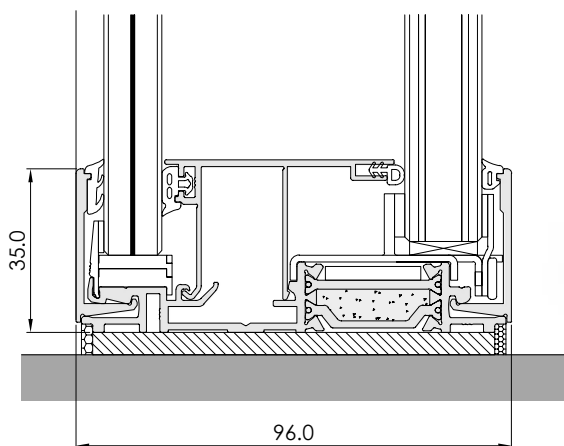
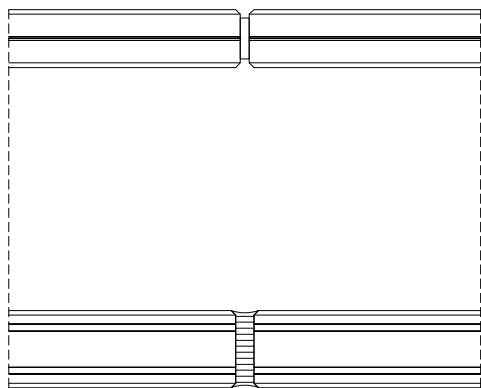

GSW Office Plus FR



GSW Office Plus FR
endoGrid



GSW Office Plus FR
egzoGrid





GSW Office doors

GSW Office doors

Doors are an integral part of the GSW Office systems. They are not only characterised by attractive appearance, but they also guarantee high acoustic parameters.

To allow mounting doors in any of the walls, system provides many variants of door frames adapted to one and two-pane glass walls as well as to the traditional partition

walls. An important advantage of the listed solutions is their compatibility with all available types of GSW Office doors – glass, aluminium-glass or wooden ones. Therefore, the investor is free to select any door across the floorplan.



FADATA | SOFIA (BG)



EasyFix is a characteristic for the entire GSW Office family convenient way of installing accessories, especially the hinges and the strike plate of the lock. The key premiss is to eliminate the need to prefabricate profiles thanks to the sliding assembly elements.

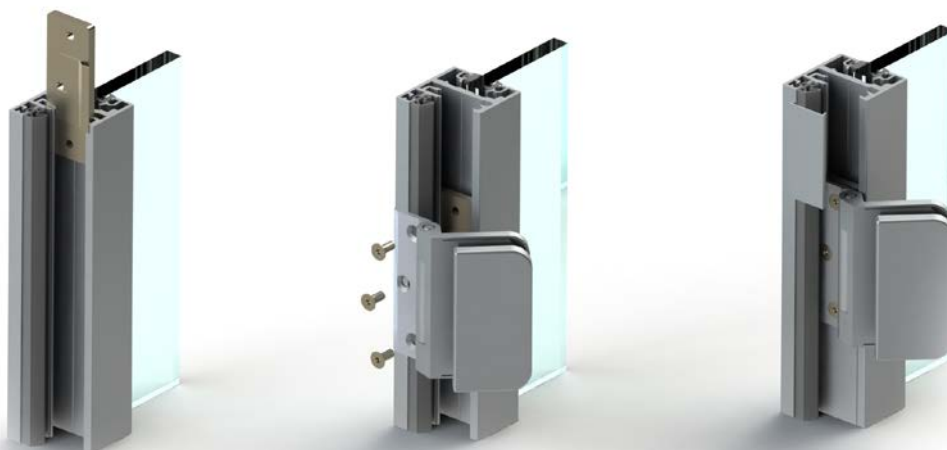

Acoustic insulation

Similarly to the walls in the GSW Office system family, doors also were subjected to laboratory tests determining the level of airborne sound insulation. Tests covered all types of doors used in the Glass System door frames. Depending on the regulations in different countries, designs can also include requirements relating to R_{A1} and $R_{A1,R}$ parameters:

$$R_{A1,R} = R_{A1} - 2 \text{ dB}$$

$$R_{A1} = R_w + C$$

Acoustic requirements according to PN-B-02151-3:2015-10* - doors

Type of room	Parameter	dB value
Office buildings		
Office rooms	$R'_{A1,R}$	≥30
Rooms for confidential talks	$R'_{A1,R}$	≥40
Conference rooms	$R'_{A1,R}$	≥35

* Polish norm concerning building acoustics, noise protection in buildings and requirements for acoustic insulation of partitions in buildings

The ranges of R_w parameter levels for GSW Office doors*:

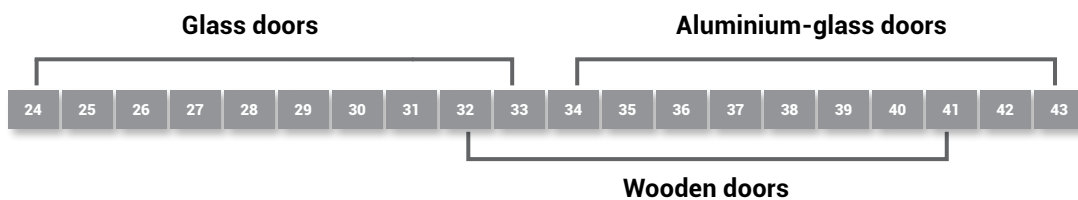

*detailed lists of acoustic insulation parameters have been included in tables next to the description of individual doors

Strength

Quality and strength tests have particular importance for doors. Therefore, the GSW Office doors underwent a series of tests in the Building Research Institute. The most important one out of these in terms of application is the test of mechanical strength, the results of which

were classified according to standard EN 12400. Obtained results show that it is possible to use GSW Office doors in places of frequent use.

Class	Conditions of use	Number of cycles
0	-	-
1	occasional	5 000
2	light	10 000
3	infrequent	20 000
4	moderate	50 000
5	normal	100 000
6	frequent	200 000
7	heavy	500 000
8	very heavy	1 000 000

Classification in accordance with EN 12400

GSW Office door frames

GSW Office H

For single-glazed GSW Office system

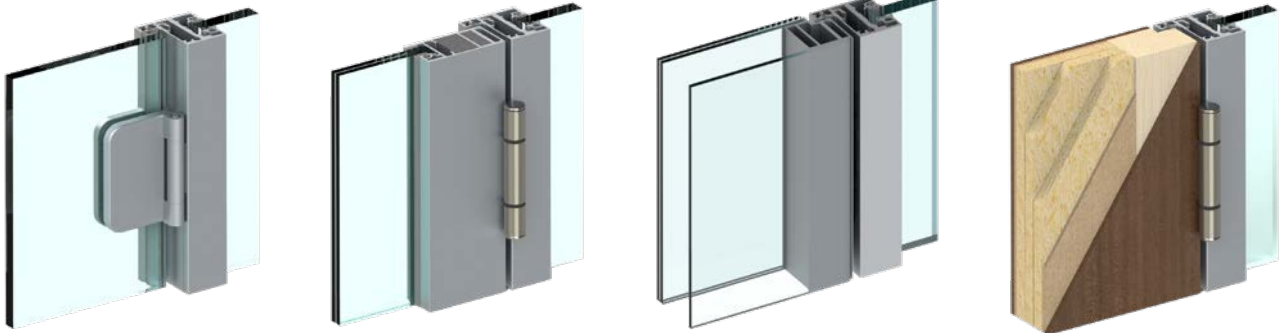
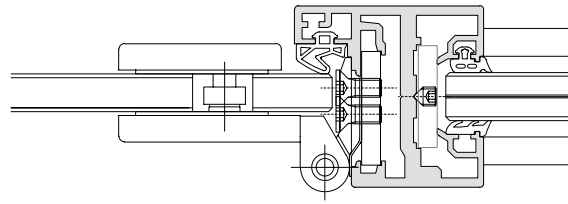

GSW Office Plus H

For double-glazed GSW Office Plus system

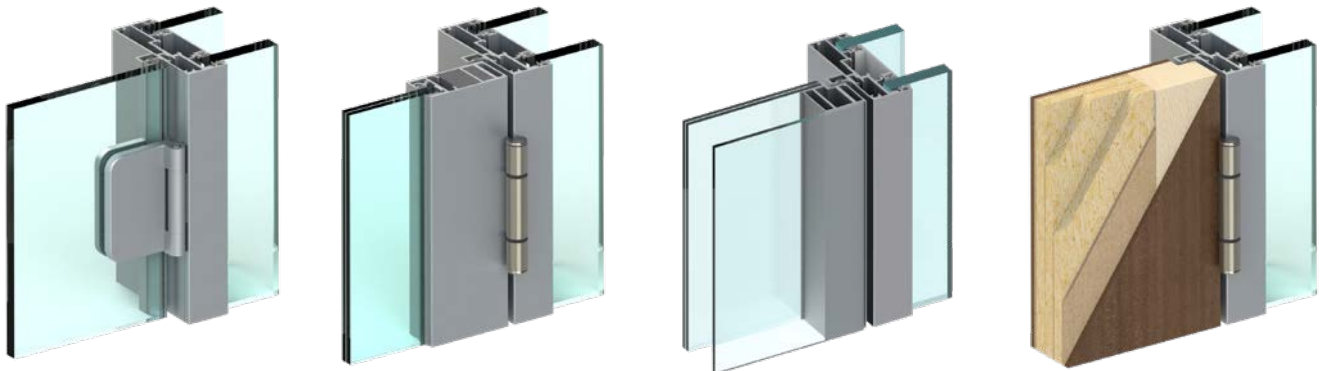
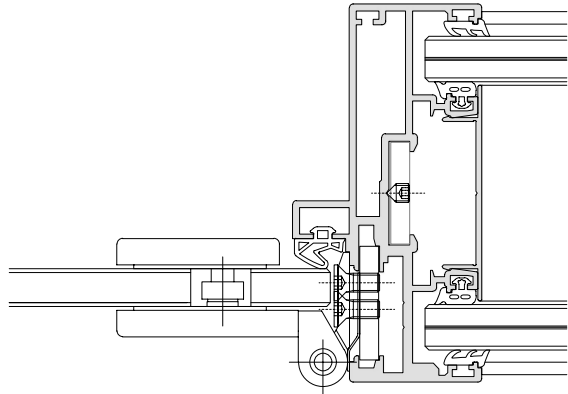

GSW Office L

Wall-adjacent door frame

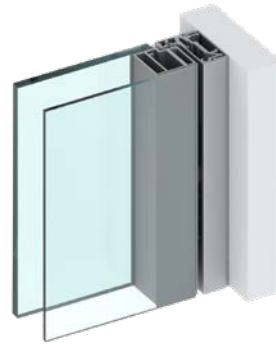
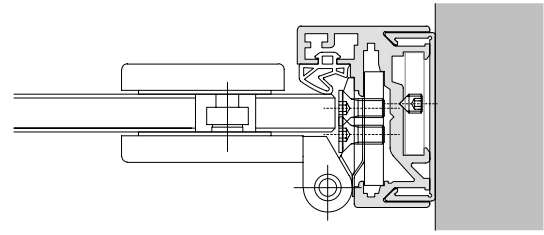

GSW Office C

Wall-covering door frame

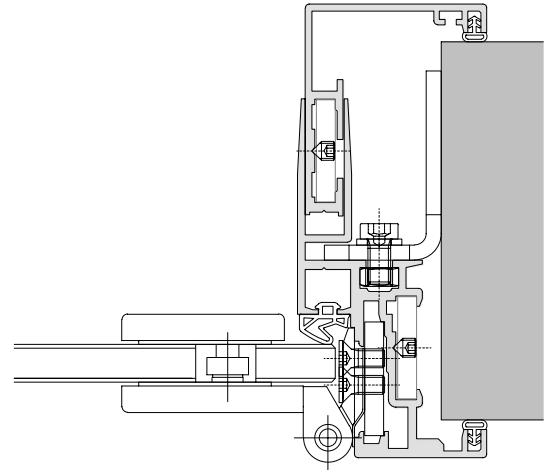

Glass doors

The door leaf made of tempered glass is mounted on an aluminum frame on the wall. This solution is characterised by the highest transparency and good acoustic insulation parameters at the same time. Its design distinguishes by visually light and delicate form, where the pane forms the effect of smooth surface in glass walls.

Specification	Durability*	Class 6 (200 000 cycles)
	Type of glass	ESG 8, 10
	Max. door leaf height (mm)	2600**
	Max. door leaf width (mm)	1000
	Acoustic insulation	R_w 24 / 32 / 33 dB; R_{A1} 24 / 31 dB
	Smoke tightness	on request
	Fire resistance	-
	Material / finish	Anodized / RAL aluminium

*according to EN 12400

**the use of a higher leaf requires consultation

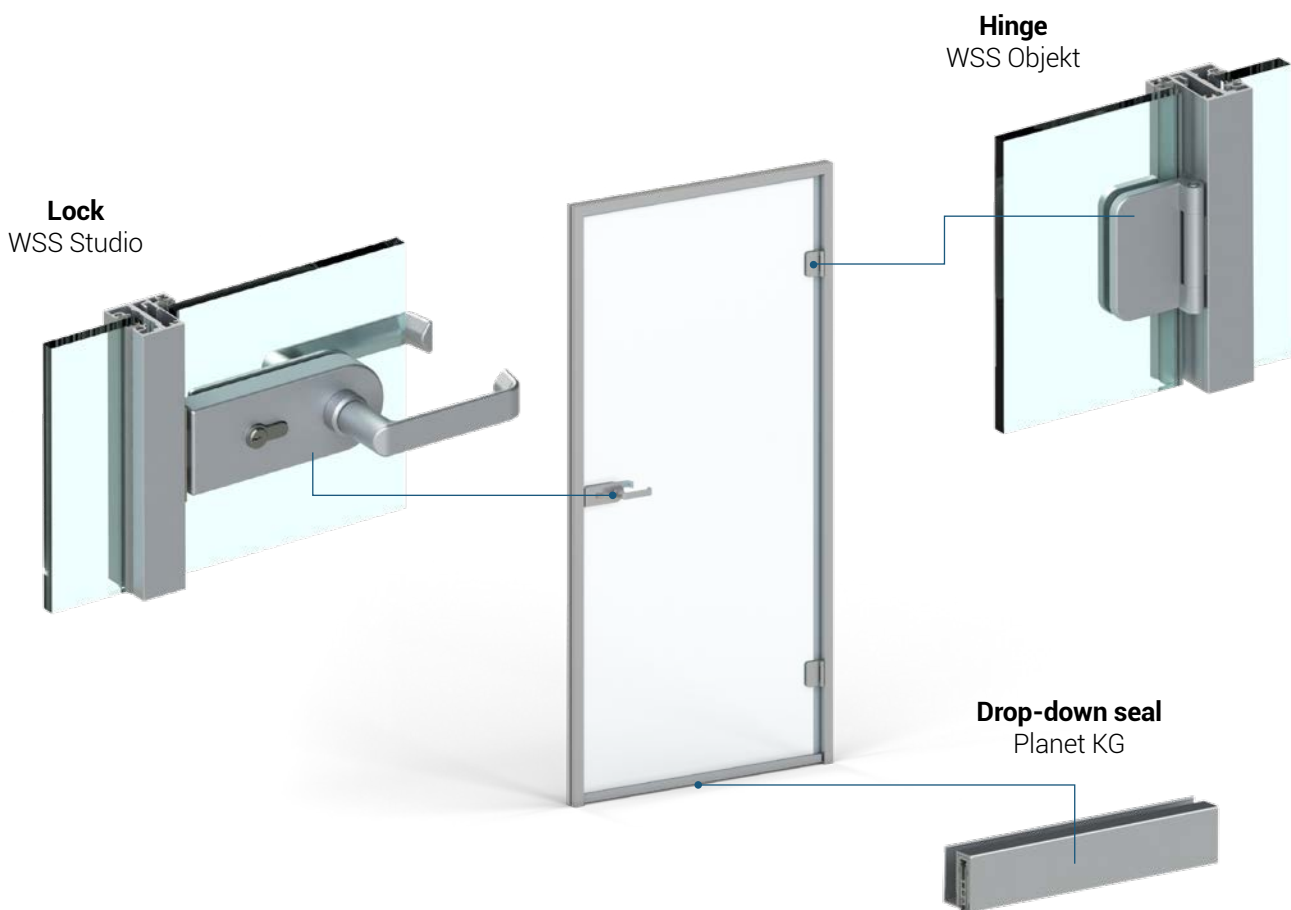

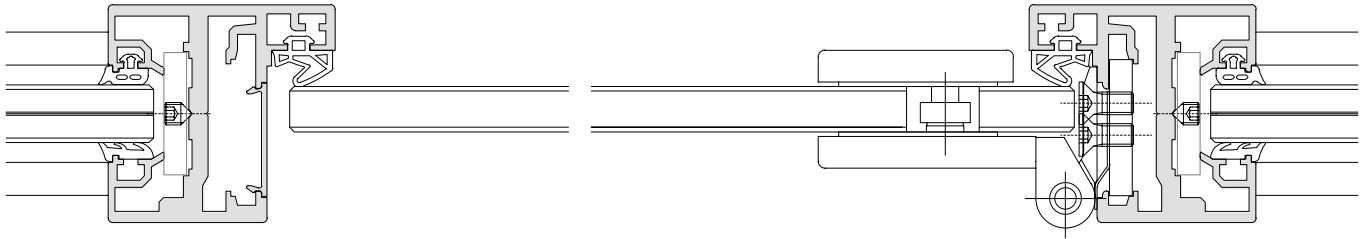

Acoustic insulation



Glass	R_w [dB]	C [dB]	R_{A1} [dB]	$R_{A1,R}$ [dB]
ESG 8 (w/o drop-down seal)	24	0	24	22
ESG 8	32	-1	31	29
ESG 10	33	-2	31	29

System drop-down seal

The system allows for the use of a drop-down seal, which seals the threshold when the door closes. The profile mounted on the bottom edge of door leaf corresponds in terms of dimensions to the profile mounting fixed glazing. The solution is based on the technology of the Swiss company Planet.

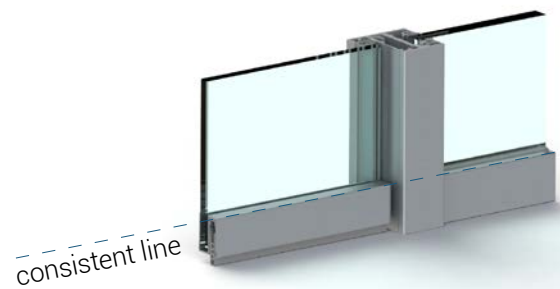

Optional accessories

Electric strike

effeff Profix2 118/138
/ GEZE Kingfix A4000/A4300



Hydraulic hinge

Colcom Biloba EVO



Door closer

GEZE TS 3000 V



Urban Slim doors

Minimalist design of glass doors in an aluminum frame. It fits well in projects characterized by a light design. The use of a frame allows the use of laminated glass, including acoustic glass, thanks to which the door offers high airborne sound insulation.

Specification	Durability*	Class 6 (200 000 cycles)
	Type of glass	VSG 44.1, 44.2, 55.1, 55.2
	Max. door leaf height (mm)	2800
	Max. door leaf width (mm)	1000
	Acoustic insulation	$R_W = 35 \div 39 \text{ dB}$; $R_{A1} = 34 \div 38 \text{ dB}$
	Smoke tightness	on request
	Fire resistance	-
	Material / finish	Anodized / RAL aluminium

*according to EN 12400



Lock
WSS 100/200 series



Drop-down seal
Planet MF-Plus

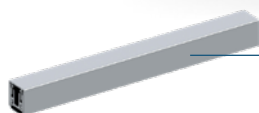

Hinge



Hidden hinge

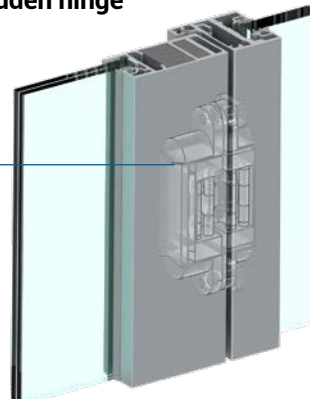

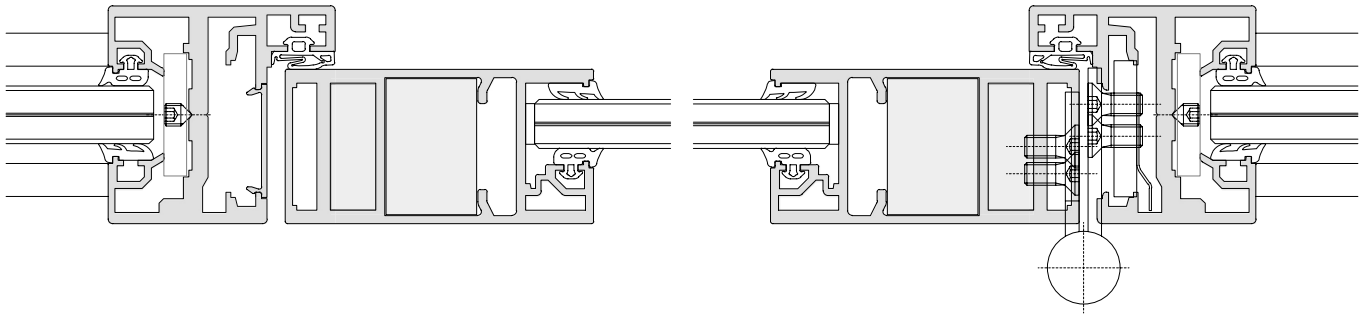

Acoustic insulation



Glass	R_w [dB]	C [dB]	R_{A1} [dB]	$R_{A1,R}$ [dB]
VSG 44.1	35	-1	34	32
VSG 44.1 + IsoSound	36	-1	35	33
VSG 44.2 Si*	37	0	37	35
VSG 44.2 Si* + IsoSound	38	-1	37	35
VSG 55.1 + IsoSound	37	-1	36	34
VSG 55.2 Si* + IsoSound	39	-1	38	36

*Si - Saint-Gobain Glass Stadip Silence

Optional accessories

Electric strike

effeff Profix2 118/138
GEZE Kingfix A4000/A4300

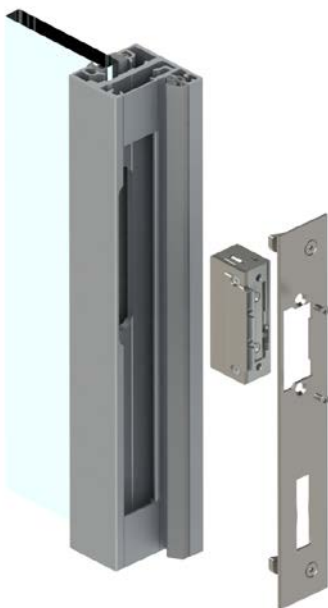

Electromechanical lock

GEZE rLock



Door closers

Surface mounted
GEZE TS 3000 V



Hidden
GEZE BOXER 2-4

Urban Plus doors

Single- or double-glazed glass doors in the Urban Plus aluminum frame. The double-glazed variant enables very high acoustic insulation - R_w up to 43 dB. The construction of the leaf in both versions allows to obtain the same high aesthetic and construction values - height range of up to 3000 mm.

Specification	Durability*	Class 6 (200 000 cycles)
	Type of glass: single-glazed	ESG 8, 10 ; VSG 44.1, 44.2, 55.1, 55.2
	Type of glass: double-glazed	ESG 6, 8 ; VSG 33.1, 33.2, 44.1, 44.2
	Max. door leaf height (mm)	3000
	Max. door leaf width (mm)	1000
	Acoustic insulation single-glazed	R_w 35 ÷ 39 dB; 34 ÷ 38 dB
	Acoustic insulation double-glazed	R_w 39 ÷ 43 dB; R_{A1} 37 ÷ 42 dB
	Smoke tightness	on request
	Fire resistance	-
Material / finish	Anodized / RAL aluminium	

*according to EN 12400



Lock
WSS 100/200 series



Drop-down seal
Planet MF-Plus

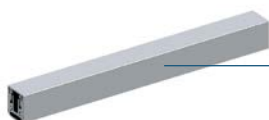

Hinge

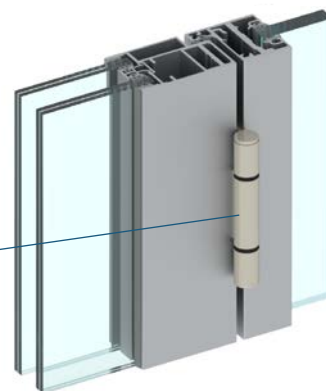

Hidden hinge

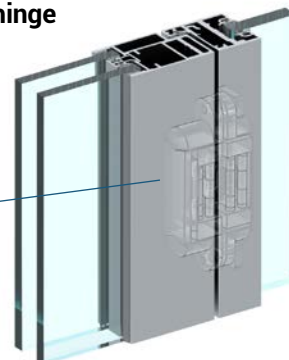

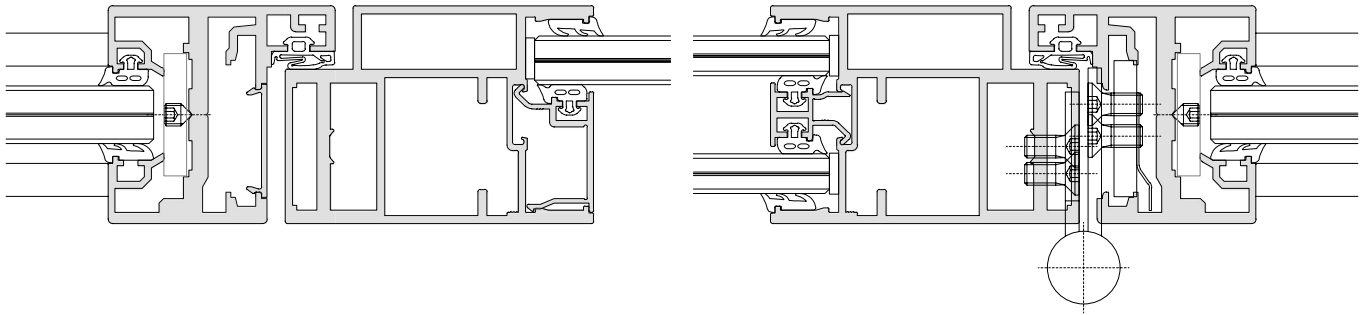

Acoustic insulation



Glass	R_w [dB]	C [dB]	R_{A1} [dB]	$R_{A1,R}$ [dB]
VSG 44.1	35	-1	34	32
VSG 44.2 Si*	38	-1	37	35
VSG 55.2 Si*	39	-1	38	36
VSG 33.1 + VSG 33.1	39	-2	37	35
VSG 33.1 + VSG 44.2 Si*	41	-1	40	38
VSG 44.2 Si + VSG 44.2 Si*	43	-1	42	40

*Si - Saint-Gobain Glass Stadip Silence

Optional accessories

Electric strike
 effeff Profix2 118/138
 GEZE Kingfix A4000/A4300

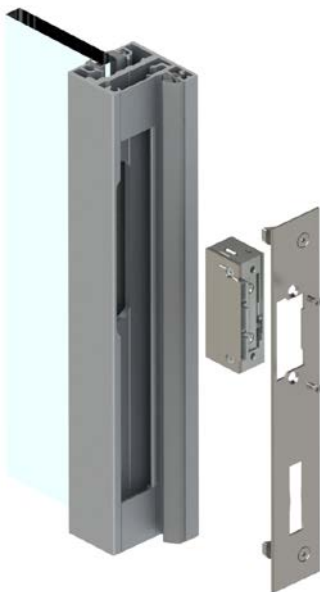

Electromechanical lock
 GEZE rLock



Door closers



Purian doors

The door leaf is characterized by the highest aesthetic values, allowing the use of not only glass as a finishing material - transparent or non-transparent - but also wood. The unique design results from the structure in which the outer material is structurally glued to the profile hidden inside the leaf. At the same time, the doors are characterized by very high acoustic insulation - R_w even up to 43 dB.

Specification	Durability*	Class 6 (200 000 cycles)
	Type of glass	ESG 4, 6 ; VSG 44.2
	Max. door leaf height (mm)	2800
	Max. door leaf width (mm)	1000
	Acoustic insulation	R_w 36 ÷ 43 dB; R_{A1} 35 ÷ 42 dB
	Smoke tightness	on request
	Fire resistance	-
	Material / finish	Anodized / RAL aluminium

*according to EN 12400



Hidden hinge

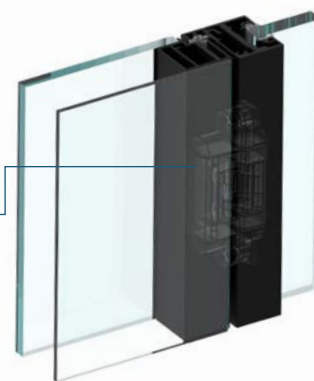

Magnetic Lock
SSF MG 50

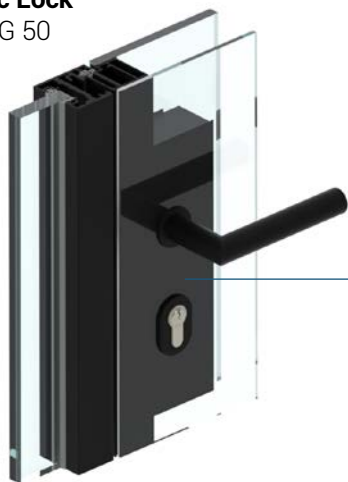

Drop-down seal
Planet MF-Plus



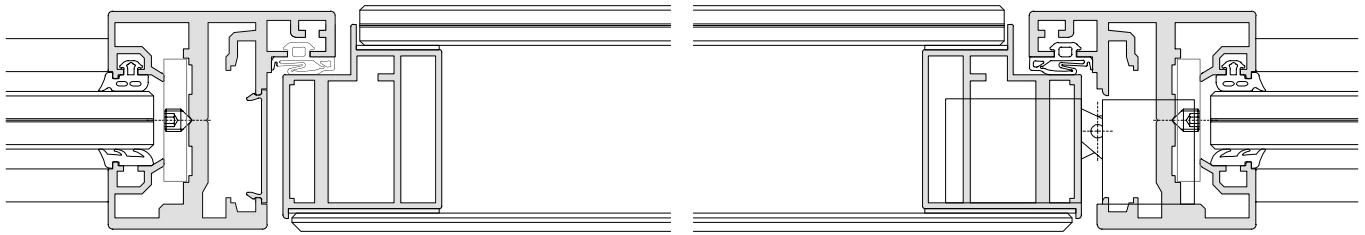

Acoustic insulation



Glass	R_w [dB]	C [dB]	R_{A1} [dB]	$R_{A1,R}$ [dB]
ESG 4 + ESG 6	36	-1	35	33
ESG 4 + VSG 44.2 Si*	40	-1	39	37
ESG 4 + VSG 44.2 Si* 	42	-2	40	38
ESG 4 + VSG 44.2 Si* (varnished)	43	-1	42	40

*Si - Saint-Gobain Glass Stadip Silence

Optional solutions

In order to increase the acoustic insulation, it is possible to use the version with the Akustic insert, which allows obtaining R_w of 42 dB while maintaining translucency.

The highest acoustic insulation for the Purian door - R_w 43 dB - is guaranteed by the door in the varnished (non-transparent) version.

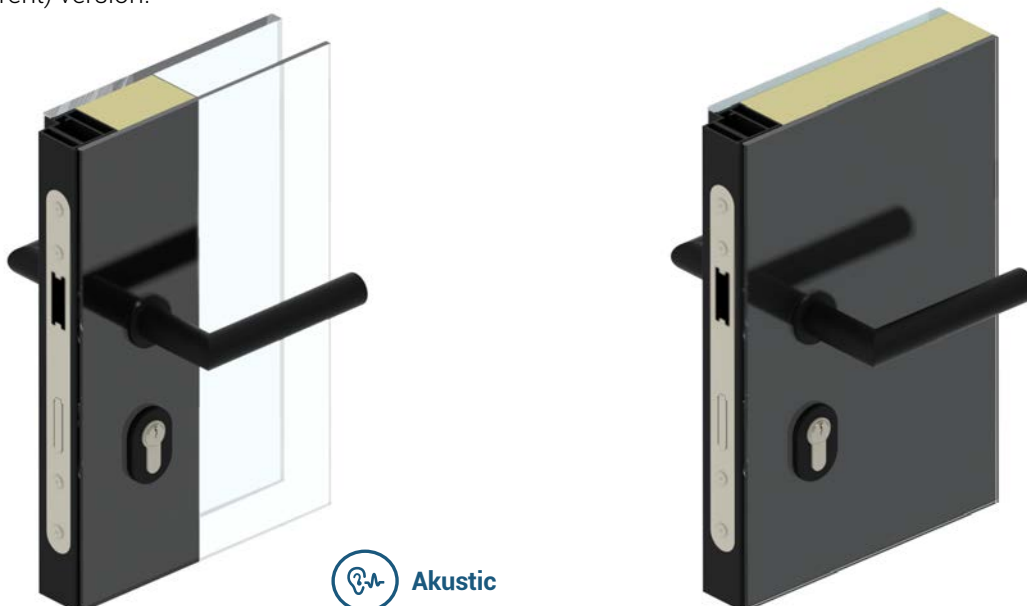

Wooden doors

The texture of the wood is the traditional and attractive door finishing. It can be selected so that it perfectly corresponds to the other interior elements. Wooden doors are great in places where we want to achieve high parameters of acoustic insulation and privacy provided by the non-transparent door.

Specification	Durability*	Class 6 (200 000 cycles)
	Type of filling	full / glazed
	Max. door leaf height (mm)	3000
	Max. door leaf width (mm)	1000
	Acoustic insulation	$R_w = 33 \div 41$ dB; $R_{A1} = 32 \div 40$ dB
	Fire resistance	-
	Material / finish	Veneer / Laminate / Varnish

*according to EN 19353:2002 / AC:2003 / C1:2007



Lock
SSF 52 series



Drop-down seal
Planet FT

Hinge

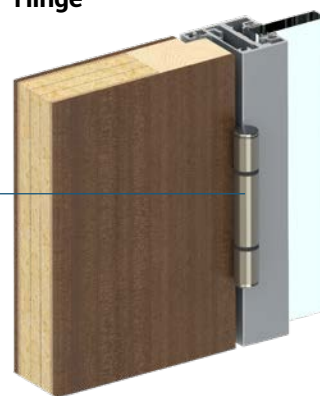

Hidden hinge

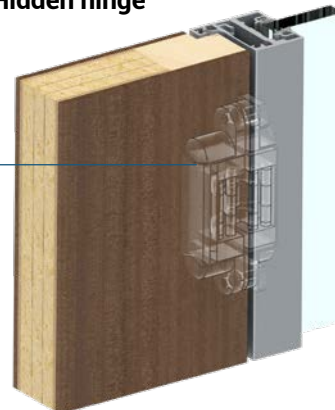

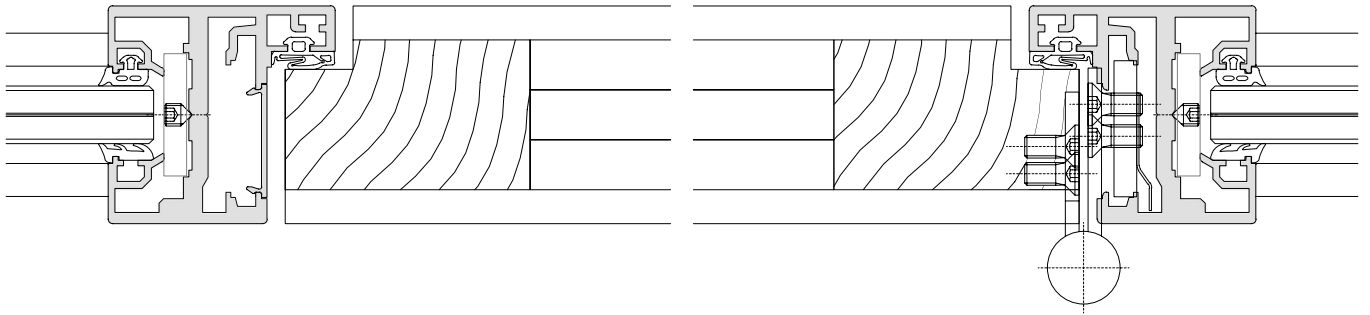

Acoustic insulation



Filling	R_w [dB]	C [dB]	R_{A1} [dB]	$R_{A1,R}$ [dB]
Glass 34 mm, VSG 44.1	33	-1	32	30
Glass 34 mm, VSG 55.2 Si*	37	-1	36	34
Solid 34 mm, Homalight D	29	-4	25	23
Solid 48 mm, Sauerland 33 VL	38	-1	37	35
Solid 48 mm Alu, Sauerland 33 VL	39	-1	38	36
Solid 48 mm, Sauerland 39S3R	41	-1	40	38

*Si - Saint-Gobain Glass Stadip Silence

Optional accessories

Electric strike

effeff Profix2 118/138
GEZE Kingfix A4000/A4300

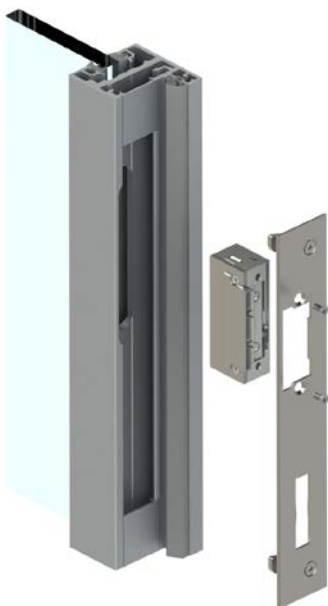

Electromechanical lock

GEZE rLock



Door closer

GEZE TS 3000 V





Fittings and accessories

Handles

For the aesthetics of the door finish, door handle and rosettes are very important. They must not only look good, but also be durable, to guarantee the stability of the entire solution.

The door handles used in the GSW Office door combine both these aspects, adding one more important - the speed of assembly without the use of tools.

Particularly noteworthy is very delicate handle's rosette, which perfectly corresponds to the light nature of the entire system.

10 10-year warranty

DIN EN ISO 14001 Environment-friendly production

Made in Europe

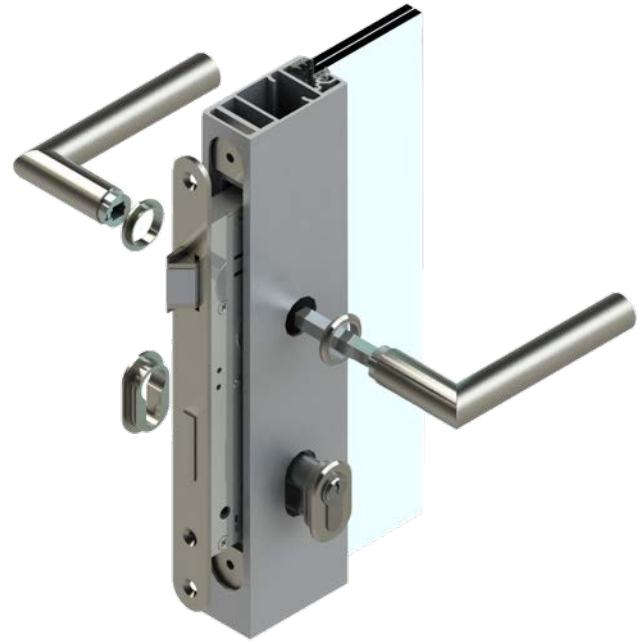

Handle type L with round form

Material	Stainless steel
Connection	Quick-Fit

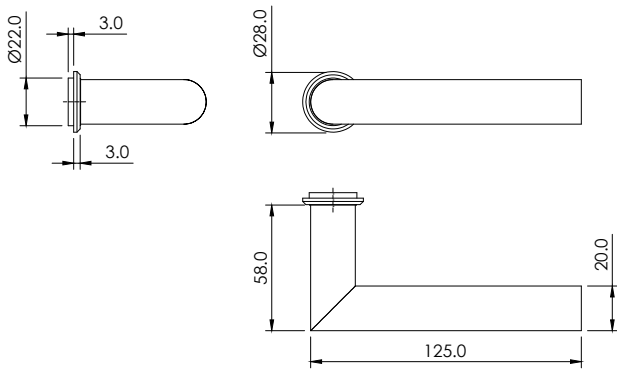

Standard finishes:

Stainless steel



Anthracite - PVD



Black - PVD



*also available in a polished, antibacterial version

Handle type L with flat form

Material	Brass
Connection	Quick-Fit

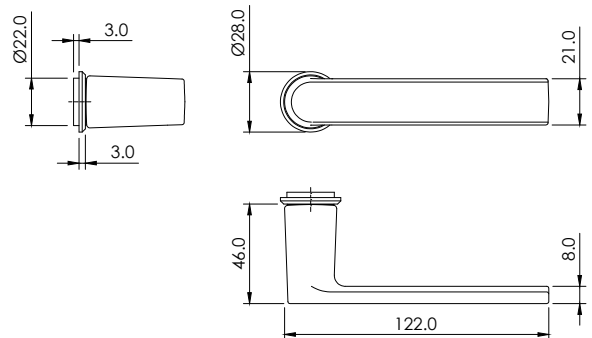

Standard finishes:

Stainless steel effect



Anthracite - PVD



Black - PVD



*also available in a polished version

Locks

Reliable fittings made by recognised German producers are used in the GSW Office doors. They ensure the highest performance and strength parameters.

Apart from testing doors in GSW systems as a whole, locks and hinges are tested additionally in laboratories of their producers and the obtained results confirm their exceptional reliability and durability

Classification*										
3	X	8	0	0	F	1	B	A	2	0
CE 3	S	5	1	0	G	6	B	C	2	0

*according to EN 12209:2003 / AC:2005



Hinges

Aluminium and wooden doors in the GSW Office systems allow the mounting of surface or concealed hinges.

The hinges used in Glass System doors are manufactured by experienced European suppliers, tested in their laboratories and are provided with the CE mark.

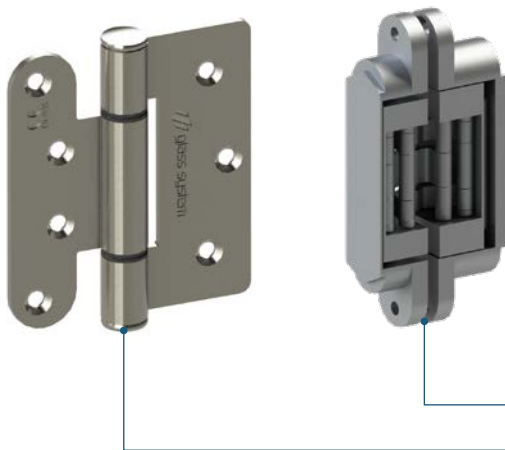

Classification*								
2	7	3	1	1	4	0	10	CE
4	7	7	1	1	4	1	14	CE

*according to EN 1935:2002 / AC:2003 / C1:2007

Drop-down seals

Drop-down seals are used as a standard to improve the acoustic insulation of every type of the doors.

All system doors use solutions based on the technology of the Swiss company Planet.

Planet
ASSA ABLOY

Planet KG	48 dB
Planet MF-Plus	54 dB
Planet FT	48 dB

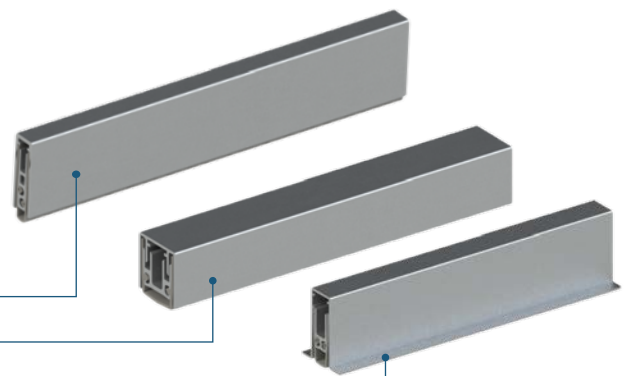

Electric strikes

One of the essential elements of modern office equipment is the access control system. In this case, an electric strike is used in the door frame and a lock with a fixed knob or handrail. The GSW Office systems allows for the use of electric strikes types:

- / effeff seria 118/138 Profix2
- / GEZE A4000/A4300 Kingfix

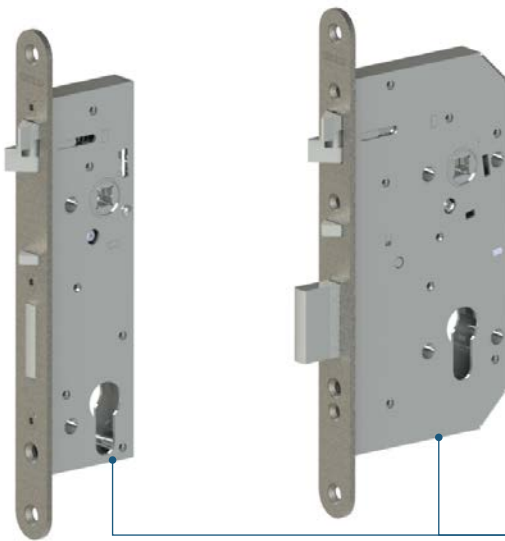

Electromechanical locks

Where access control and simultaneous mechanical protection are required, self-locking electromechanical locks can be used. When closing the door, the bolt is automatically released, which effectively locks the door in the closed position. If an opening signal is given, the lock activates the handle enabling free access. The locks meet the requirements of panic and emergency outputs in accordance with EN 179 and EN 1125.

The GSW Office systems uses GEZE rLock electromechanical locks.

Classification*									
3	7	6	B	1	3	2	2	A	B/D

*according to EN 179:2008

Door closers

The door closers are particularly important when using the access control system. The closing of the door is effectively controlled after each opening. The door closer can remain in the open position after the use of mechanical interlocks.

The GSW Office systems has been adapted to work with GEZE TS 3000 V door closer, and in the case of aluminium doors there is also the option of installing a hidden door closer - GEZE Boxer 2-4.

Classification*					
4	8	4	1	1	4
3	8	4	1	1	4
		2			

*according to EN 1154:1996 / A1:2002

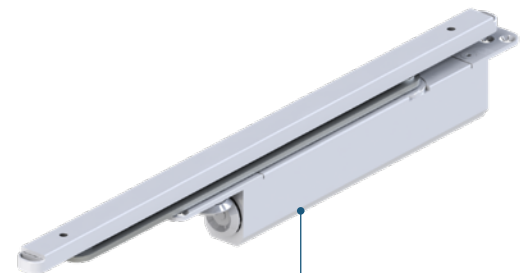
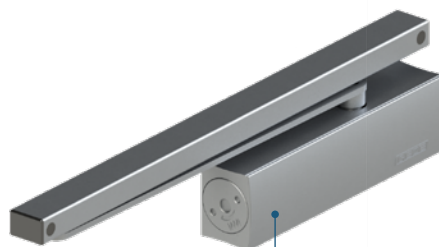

Glass fittings

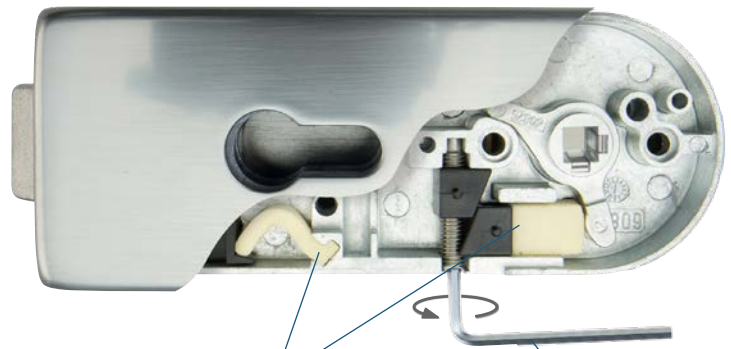

polymeric elastic elements

possibility of adjusting resistance of the handle

Locks

Durability (DIN EN 12209)	1 500 000 cycles
Corrosion resistance (DIN EN 1670)	class 3

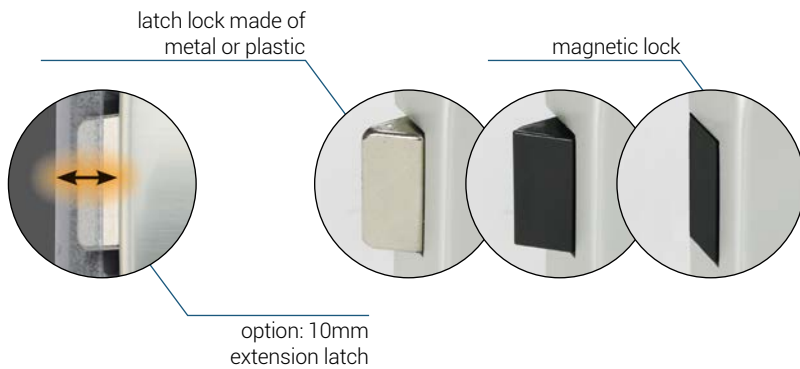

Handles

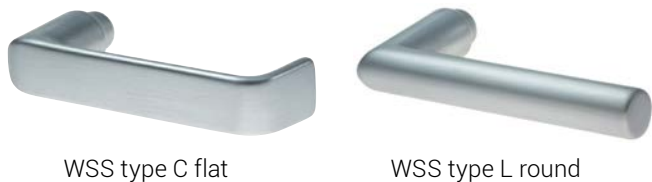

Hinges

Load capacity (DIN EN 1935)	60 kg
Durability (DIN EN 1935)	500 000 cycles



WSS Objekt

More fittings and information in WSS catalogues





Lante Intelli switches and readers

What complements GSW Office systems perfectly are minimalist Lante Intelli light switches and access control readers. With their delicate and elegant form, they are a perfect match for the other solutions, forming a visually

consistent whole. A small touch panel with subtle backlight is adapted to the aluminium profiles of the frame in terms of dimensions.



Lante Intelli Touch

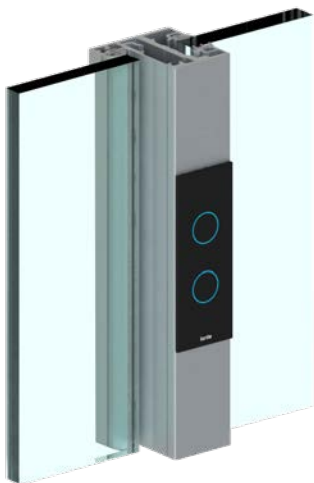

Lante Intelli Gestiq

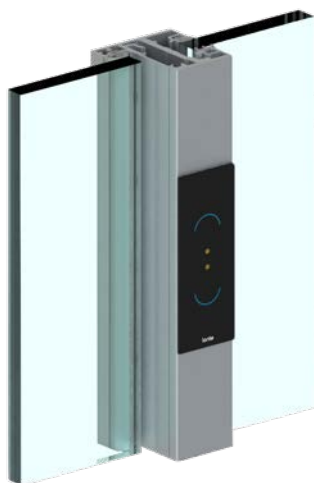

Lante Intelli Access



12V



Wall Up baseboards

Baseboards are a small but significant part supplementing the products of the GSW Office family. They are consistent in their appearance and dimensions with other system profiles. Additionally, it is possible to run cables inside

the baseboard, which improves the functionality and aesthetics of the interior.

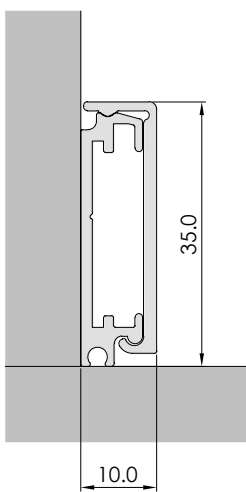

35
mm I

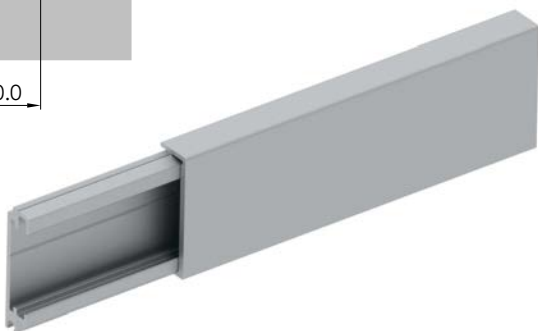

wall up
THE BASEBOARDS



More information in
Wall Up catalogue

Sales materials



Demonstration model
GSW Office

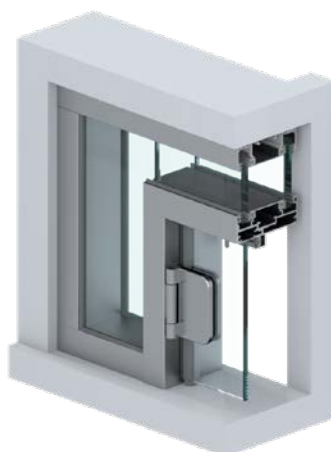

Demonstration model
GSW Office Plus



Demonstration model
GSW Office FR



Demonstration model
GSW Office Plus FR



Color swatch

Glass System catalogues



GSW Office



GSW Pro



GS Railing

Test reports

LA01-1839/15/Z00NA
LA02-1839/15/Z00NA
LZF00-01468/16/Z00NZF
LZF01-01028/17/Z00NZF
LZF02-01028/17/Z00NZF
LZF00-02459/16/Z00NZF
LZF01-02255/17/Z00NZF
LZF02-02255/17/Z00NZF
LZF03-02255/17/Z00NZF
LZF00-02392/17/Z00NZP
LZF00-02577/18/Z00NZF
LZF00-03592/18/Z00NZF
LZF01-03295/18/Z00NZF
LZF02-03295/18/Z00NZF
LZF01-01708/19/Z00NZF
LZF02-01708/19/Z00NZF
LZF03-01708/19/Z00NZF
LZF04-01708/19/Z00NZF
LZF05-01708/19/Z00NZF
LZF00-02062/19/Z00NZF
LZF00-03171/19/Z00NZF
LZF00-03582/19/Z00NZF
LZF01-00763/20/Z00NZF
LZF02-00763/20/Z00NZF
LZF00-01287/20/Z00NZF
LZF02-01401/20/Z00NZF
LZF01-01401/20/Z00NZF
LK01-02944/15/Z00NK
LK02-02944/15/Z00NK
LK03-02944/15/Z00NK
LZE00-02599/16/Z00NZE

LZE00-01313/17/Z00NZE
LZE00-02392/17/Z00NZP
LZE01-02776/19/Z00NZE
LZE02-02776/19/Z00NZE
LZE01-02777/19/Z00NZE
LZE01-02783/19/Z00NZE
LZE02-02783/19/Z00NZE
LZE00-00889/20/Z00NZE
LZE01-01457/20/Z00NZE
LZE02-01457/20/Z00NZE
LZE03-01457/20/Z00NZE
LZP01-02392/17/Z00NZP
LZP02-02392/17/Z00NZP
LZP03-02392/17/Z00NZP
LZP04-02392/17/Z00NZP
LZP05-02392/17/Z00NZP
LZP01-02867/18/Z00NZP
LZP01-03326/19/Z00NZP
LZP02-03326/19/Z00NZP
LZP01-03337/19/Z00NZP
LZP01-00717/20/Z00NZP
LZP02-00717/20/Z00NZP
LZP01-01532/20/Z00NZP
LZP02-01532/20/Z00NZP
LZP03-01532/20/Z00NZP
LZP04-01532/20/Z00NZP
LZP05-01532/20/Z00NZP
LZP01-01576/20/Z00NZP
LZP01-01577/20/Z00NZP
LZP00-01778/20/Z00NZP

List of reports from tests carried out by the Glass System Research and Development Center* at the Building Research Institute, within which the system parameters specified in the catalog were obtained.

*status granted by the Ministry of Economic Development of the Republic of Poland by Decision No. 1 / CBR / 20



 +48 22 243 24 20

 office@glasssystem.com

www.glasssystem.com