

**sapa:**

# Sapa Door 2086/2086 SX

High insulated door with high weather tightness



# Sapa Door 2086 and 2086 SX

Door 2086 has 86 mm deep profiles, basic insulation level with 42 mm of glass fibre reinforced polyamide strips. For optimum energy performance, choose Door 2086 SX with Sapa Thermo N9 insulating strips in profiles.

System can be specified with choice of three seal performance levels: Standard, Plus and Extreme.

Door leaf profiles are available for narrow and modular locks. Rebate for glass and infill panel 20–56 (64) mm. The outer glazing bead is integrated in the door profile for asymmetrically installed glazing units. These doors can easily be combined with our Facade Systems 4150, 5050 SG and Glazed Elements 3086.

2086 is a highly insulated door. 2086 SX also has Sapa Thermo N9 insulating strips. The door system can be specified with choice of three seal performance levels.

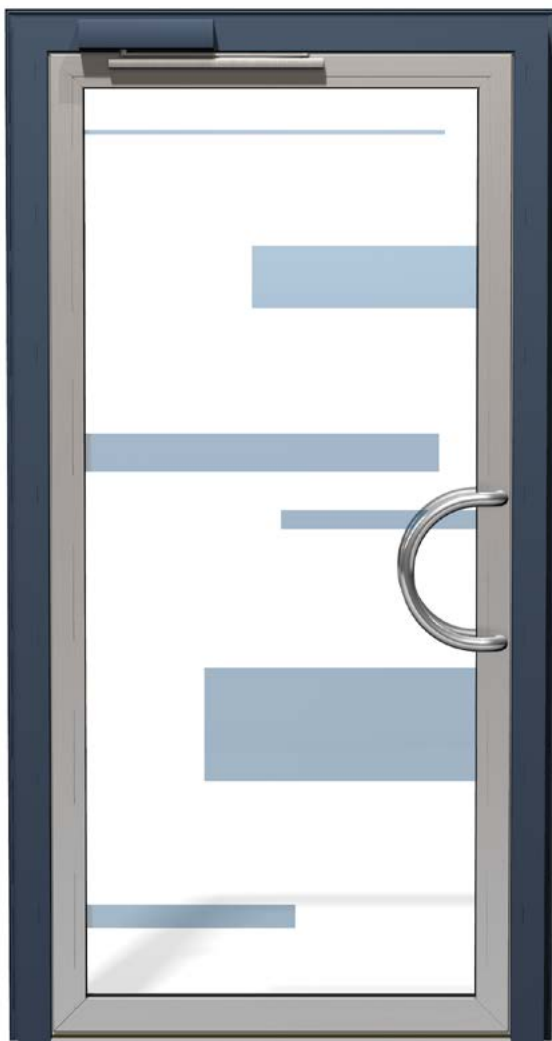

*Door 2086 design example*

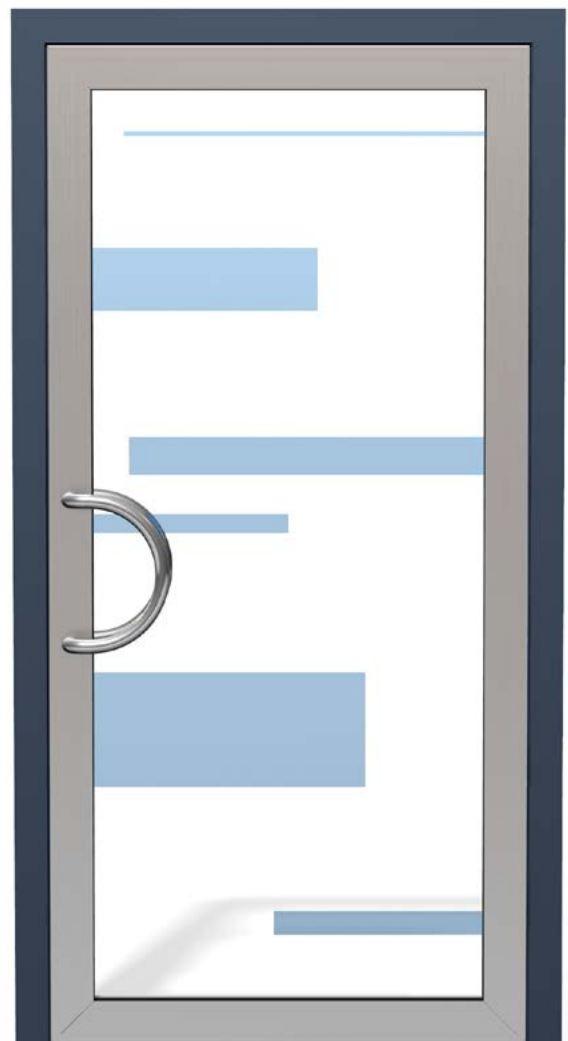

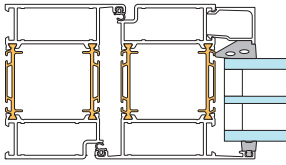

Sapa Door 2086

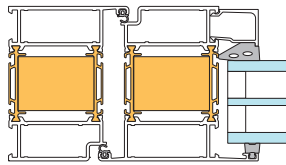

Sapa Door 2086 SX

Sapa Door Systems	2086 and 2086 SX		
	Standard	Plus	Extreme
System specification			
Single door	▪	▪	▪
Double doors	▪	▪	
Lock type	Single-point	Single-point	Three-point
Door sill options	6	3	2
Universal hinge	▪	▪	▪
Butt hinge	▪		
Concealed hinge	▪	▪	▪
Door leaf size max., mm	1350x3000	1350x2500	1350x2500
Glass thickness max., mm	56 (64)	56 (64)	56 (64)
Weight max., kg	200	200	200
Airtightness, class according to EN 12207	n/a	2	4
Watertightness classification according to EN 12208	n/a	4A	9A
Wind load classification according to EN 12210	n/a	C2	C3
Repeated opening/closing, classification according to EN 12400	6	6	6
Design choice	Narrow or modular profiles.		
Child safety, anti-finger trap device	Rubber profile/ membrane	Membrane	Membrane
Maintenance	Replaceable rebate section on frame side.		



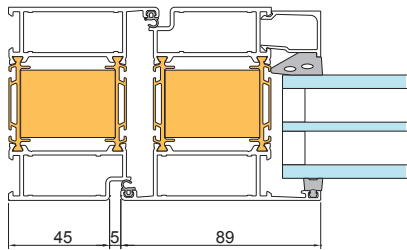
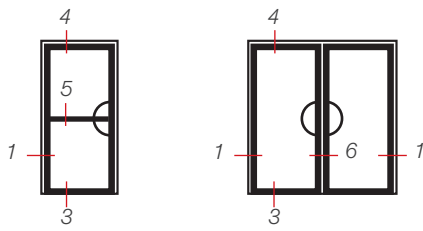

1 - Door with narrow profile. Illustration shows Door 2086 SX with Sapa Thermo N9 insulating strips in profiles

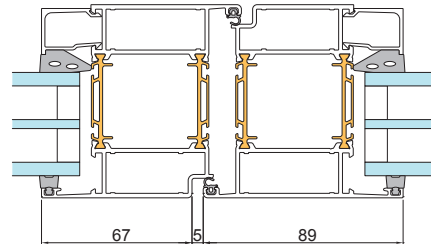
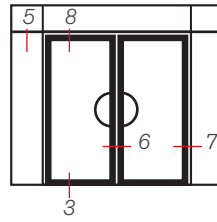

6 - Double doors, narrow profile

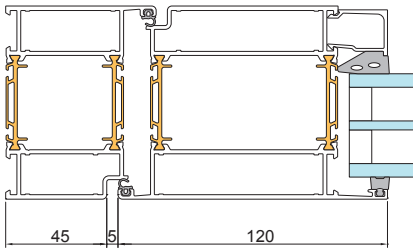

1 - Door with modular profile

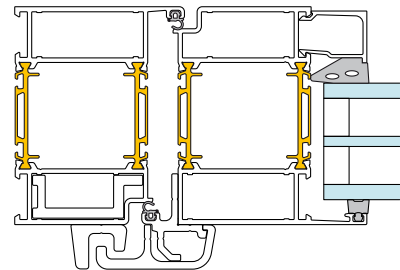

10 - Reinforced rebate section

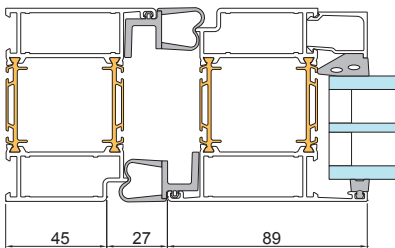

1 - Door 2086 standard with anti-finger trap device, narrow profile

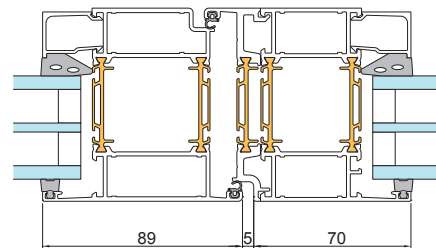

7 - Door with side light. Narrow profile with replaceable rebate section

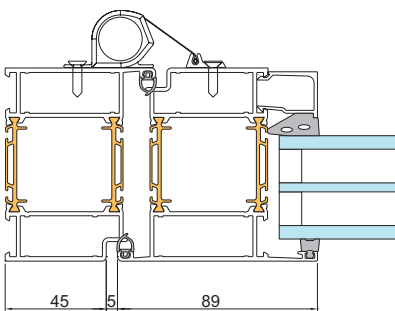

1 - Door 2086, Plus and Extreme, with anti-finger trap device, narrow profile

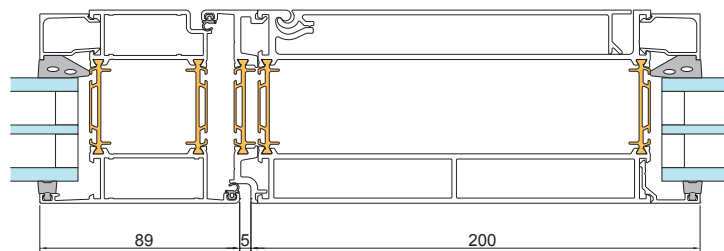

10 - Door with narrow profile and E-frame for integrated electronics

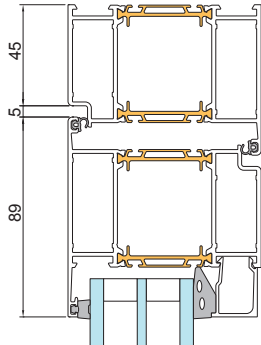

4 - Top edge of door with frame

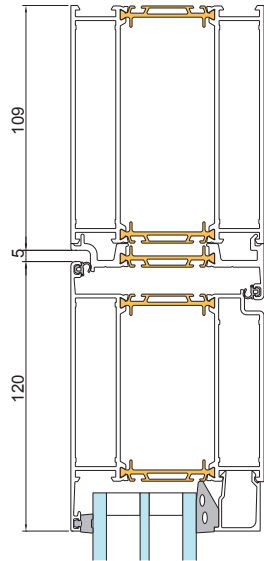

4 - Top edge of door with profile for automated swing door

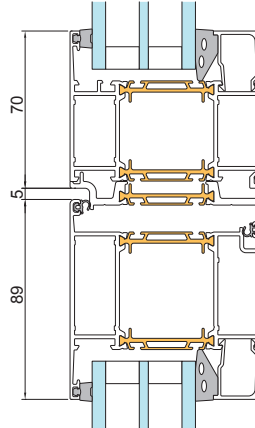

8 - Top edge of door with top light

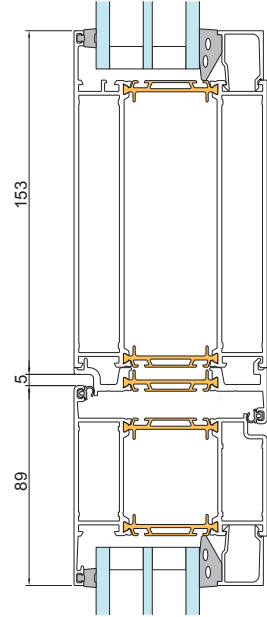

8 - Top edge of door with top light and profile for automated swing door

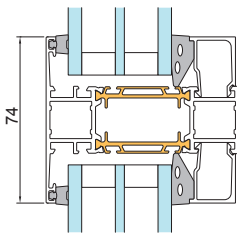

5 - Glazing bars

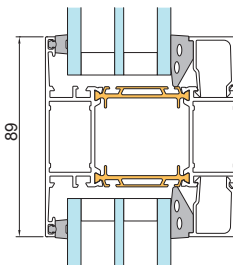

5 - Glazing bars

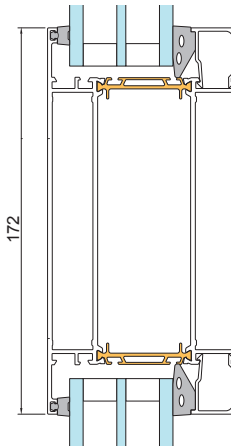

5 - Glazing bars

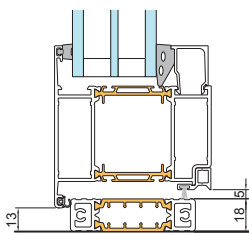

3 - Specification: Door 2086

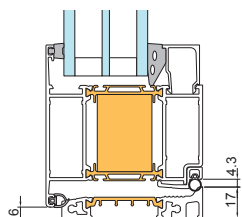
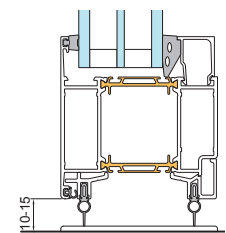
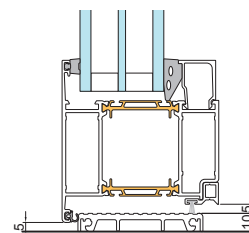
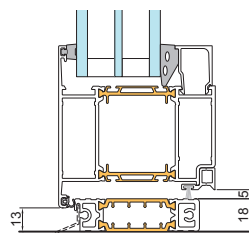
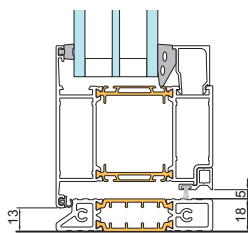

3 - Specification: Door 2086 SX Plus

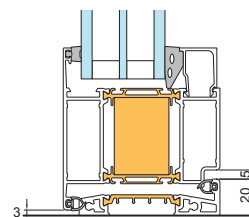
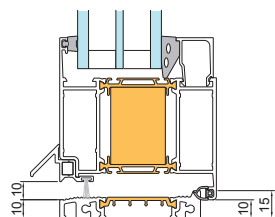

Specification: Door 2086 SX Extreme

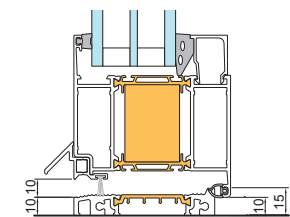









**Typical U-values Sapa Door System 2086**

		Fully glazed single door without glazing bars			Glazed single door with glazing bars			Fully glazed double door without glazing bars			Glazed double door with glazing bars		
U-values glass ( $U_g$ ) in $W/m^2K$		0.5	0.6	0.7	0.5	0.6	0.7	0.5	0.6	0.7	0.5	0.6	0.7
B	H	U-values door ( $U_d$ ) in $W/m^2K$											
1000	2200	1.1	1.2	1.2	1.2	1.2	1.3						
1200	2200	1.0	1.1	1.2	1.1	1.2	1.2						
1600	2200							1.1	1.2	1.2	1.2	1.2	1.3
2000	2200							1.0	1.1	1.2	1.1	1.1	1.2
2400	2200							1.0	1.0	1.1	1.0	1.1	1.2

**Typical U-values Sapa Door System 2086 SX**

1000	2200	0.9	1.0	1.1	1.0	1.0	1.1						
1200	2200	0.9	1.0	1.0	0.9	1.0	1.1						
1600	2200							0.9	1.0	1.1	1.0	1.0	1.1
2000	2200							0.9	1.0	1.0	0.9	1.0	1.1
2400	2200							0.8	0.9	1.0	0.9	1.0	1.0

*U-value door,  $U_d$  is based on narrow profile and given in  $W/m^2K$ . U-value for glass,  $U_g$  refers to centre point measurement and is given in  $W/m^2K$ . Glass, triple-glazed unit with warm edge, thickness 42 mm. Glazing bar width 74 mm. All values with insulated rebate door sill.*

Typical sound reduction values. Sapa Door Systems	2086 SX Plus		
	Sound reduction values		
Typical sound values, fully glazed single door, size 1180x2130 mm.	$R_w$	$R_w+C$	$R_w+C_{tr}$
Glass T4-16-4-16-4. NSG Pilkington	34	33	29
Glass T6-16-4-16-8.8. NSG Pilkington	42	41	37
Glass TS 51/50. SGG Emmaboda Glass	44	43	38
	Sound reduction values		
Typical sound values, solid fill panel in single door, size 1180x2130 mm. *	37	35	31

\* Solid infill panel, thickness 53 mm, construction from outside inwards:

- 1.5 mm aluminium sheet
- 5 mm wood fibre
- 40 mm closed cell plastic
- 5 mm wood fibre
- 1.5 mm aluminium sheet



**Clear dimension, Sapa 2086**

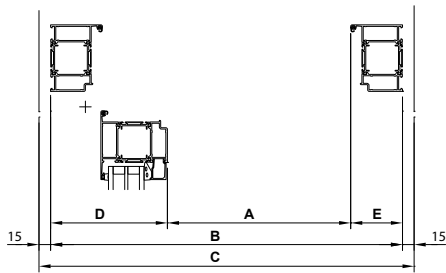

Rebate door

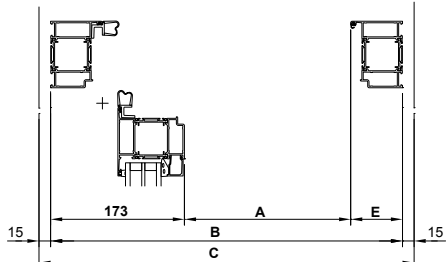

Door with anti-finger trap device, rubber seals

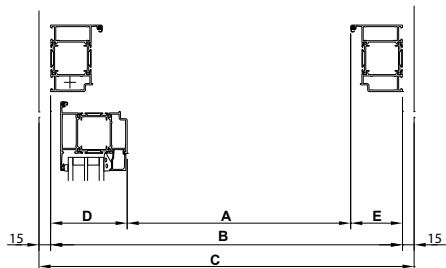

Door with concealed hinge

A= Free opening  
B= Frame outer dimensions  
C= Wall opening

Universal hinge:  
D= 151 mm  
with replaceable rebate

Butt hinge:  
D= 145 mm  
with replaceable rebate  
D= 148 mm

Concealed hinge:  
D = 98.5 mm  
with replaceable rebate:  
D = 101.5 mm

Integrated rebate:  
E= 67 mm  
Replaceable rebate sections  
E= 70 mm

**Glass, Sapa 2086**

Glass thickness 20-64 mm

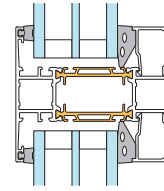

**Glazing unit, symmetrically installed, Sapa 2086**

Glass thickness 32-42 mm

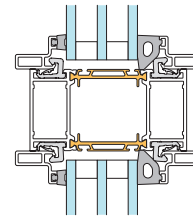

**Attachment alternatives, Sapa 2086**

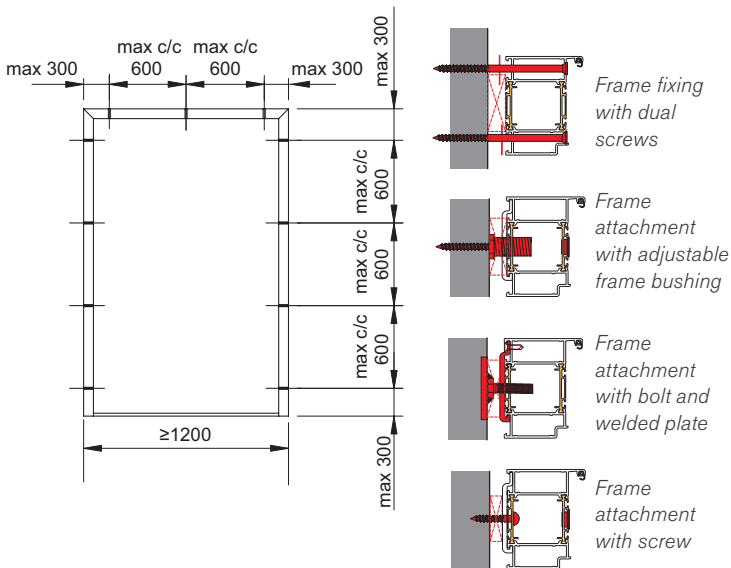

Single doors  $\geq 1200$  mm and double doors must be fixed at the top edge.  
Door element must be attached to a suitable rigid wall structure.  
The choice of fixing method depends on the wall type.

**Infill panels, Sapa 2086**

Infill panel F1  
1.5 mm aluminium sheet  
max. 60 mm  
insulation 1.5 mm  
aluminium sheet

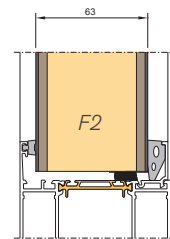

Infill panel F2  
1.5 mm aluminium sheet  
4.8 mm board max. 50  
mm insulation 4.8 mm  
board 1.5 mm aluminium  
sheet

Infill panel F3  
1.5 mm aluminium sheet  
max. 50 mm  
insulation 10 mm  
chipboard 1.5 mm  
aluminium sheet

Read more in section  
on Glazed Elements.

# Fittings

**Design the entire solution.** Our system solutions offer many different possible combinations. A selection is shown below.



2086/2074/2050 narrow profile, outside.

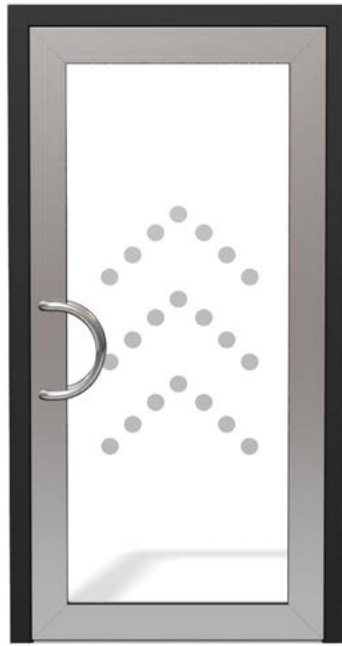

2086/2074/2050 modular profile, outside.

## Door handles and levers.



**Semicircular handle** with concealed attachments. Height 300 mm, Ø 30 mm. Aluminum or stainless steel.



**Triangular handle** with concealed attachments. Height 300 mm, Ø 30 mm. Aluminum.



**Offset handle** with concealed attachments. Height 300 mm, Ø 30 mm. Aluminum.



**Lever handle for inner door**  
Lever handle, knob, rosette and cylinder rosette with modular profile. Width 137 mm, Ø 21 mm.



**Universal hinge.**



**Lap butt hinge.**



**Concealed hinge.**



# sapa:

## Hydro Building Systems Lithuania UAB

Kirtimų g. 47  
LT-02244 Vilnius  
T +370 5 210 2587  
E [sapa.lt@hydro.com](mailto:sapa.lt@hydro.com)  
[www.sapa.lt](http://www.sapa.lt)

By  Hydro